



DRAGON™

Reference Manual



DRAGON™

REFERENCE MANUAL





DATALOGIC S.p.A.
Via Candini 2
40012 - Lippo di Calderara di Reno
Bologna - Italy

DRAGON™ REFERENCE MANUAL

Ed.: 07/2004

This manual refers to
the following software versions:

for DRAGON™ D **SW 3.00** and later

for DRAGON™ M **SW 3.00** and later

ALL RIGHTS RESERVED

Datalogic reserves the right to make modifications and improvements without prior notification.

Datalogic shall not be liable for technical or editorial errors or omissions contained herein, nor for incidental or consequential damages resulting from the use of this material.

Product names mentioned herein are for identification purposes only and may be trademarks and or registered trademarks of their respective companies.

© Datalogic S.p.A. 2001-2004

Rev. B

CONTENTS

	GENERAL VIEW	ix
1	INTRODUCTION	1
2	INSTALLATION.....	2
2.1	DRAGON™ D Interface Cable Connections.....	2
2.2	OM-DRAGON™ Interface Cable Connections.....	3
2.3	RS232 Connection.....	4
2.4	WEDGE Connection.....	4
2.5	PEN Emulation Connection.....	5
2.6	Network Connections.....	5
2.6.1	OM-DRAGON™ Network Connectors.....	5
2.6.2	Network Cabling.....	6
2.6.3	Network Termination.....	7
2.7	DRAGON™ M Battery Maintenance.....	7
2.7.1	Battery Type.....	7
2.7.2	Battery Charging.....	8
2.7.3	Replacing DRAGON™ M Batteries.....	8
2.8	Mounting The OM-DRAGON™ / C-DRAGON™ Cradle	10
2.8.1	Portable Desktop Use	11
2.8.2	Fixed Desktop Use.....	12
2.8.3	Wall Mounting	13
2.8.4	Alignment Plate Installation.....	14
3	DRAGON™ M SYSTEM AND NETWORK LAYOUTS.....	15
3.1	Stand Alone Layouts.....	15
3.1.1	Single Reader Layout.....	15
3.1.2	Multiple Reader Layout.....	15
3.1.3	Multiple Stand Alone Layouts.....	16
3.1.4	C-Box Layout	17
3.2	Multidrop STAR-System™ Network Layouts	18
3.2.1	Host Master Layout.....	18
3.2.2	OM-DRAGON™ Master Layout.....	19
3.2.3	Master OM-DRAGON™ Network Troubleshooting.....	20
4	CONFIGURATION.....	21
4.1	Configuration Methods.....	21
4.1.1	Reading Configuration Barcodes	21
4.1.2	Using DL Sm@rtSet.....	21
4.1.3	Copy Command.....	21
4.1.4	Sending Configuration Strings from Host.....	22
4.2	Setup Procedures	22

4.3	DRAGON™ D Setup.....	23
4.4	DRAGON™ M/OM-DRAGON™ Stand Alone Setup.....	23
4.4.1	Using Multiple M-Series Readers With Same Cradle.....	25
4.4.2	DRAGON™ M/STAR-Modem™ in Stand Alone Mode	26
4.5	DRAGON™ M/STAR-System™ Setup	27
4.6	OM-DRAGON™ STAR-System™ Network Setup	29
4.7	Interface Selection	31
4.8	Changing Default Settings	35
	RS232 PARAMETERS	36
	Baud Rate	37
	Parity.....	38
	Data Bits	38
	Stop Bits.....	39
	Handshaking.....	39
	ACK/NACK Protocol.....	40
	FIFO.....	40
	Inter-Character Delay.....	41
	Rx Timeout.....	41
	Serial Trigger Lock (D Series Only)	42
	WEDGE PARAMETERS	43
	Keyboard Nationality.....	44
	Caps Lock.....	46
	Caps Lock Auto-recognition.....	46
	Num Lock.....	47
	Inter-Character Delay.....	48
	Inter-Code Delay.....	48
	Keyboard Setting	49
	Control Character Emulation.....	51
	PEN EMULATION	52
	Operating Mode.....	53
	Minimum Output Pulse.....	54
	Conversion To Code 39 and Code 128.....	55
	Overflow.....	56
	Output Level.....	56
	Idle Level.....	57
	Inter-Block Delay.....	57
	NETWORK PARAMETERS	58
	RS485 Network.....	59
	Network Baud Rate.....	60
	Slave Address Range	60
	Warning Message	61
	Master Cradle Header.....	62

Master Cradle Terminator	63
DATA FORMAT	64
Code Identifier	67
Custom Code Identifier	68
Header	69
Terminator.....	70
Field Adjustment	71
Field Adjustment Character.....	72
Code Length Tx	72
Character Replacement	73
Address Stamping (M Series only).....	75
Address Delimiter (M Series only).....	75
Time Stamping (M Series only).....	76
Time Stamping Delimiter (M Series only).....	76
POWER SAVE.....	77
Sleep State	78
Enter Sleep Timeout	78
READING PARAMETERS	79
Trigger Type.....	80
Trigger Signal.....	80
Trigger-Off Timeout.....	81
Flash Mode	81
Reads per Cycle	82
Safety Time.....	82
Beeper Intensity	83
Beeper Tone	83
Aiming System	84
DECODING PARAMETERS.....	85
Ink-Spread	86
Overflow Control	86
Interdigit Control.....	87
Decoding Safety.....	87
Puzzle Solver™	88
CODE SELECTION	89
EAN/UPC Family	91
2/5 Family	95
Code 39 Family.....	96
Code 128 Family.....	98
Code 93	99
Codabar Family.....	100
MSI.....	102
Plessey	103

Telepen	104
Delta IBM	105
Code 11	106
Code 16K	107
Code 49	107
RSS Codes	108
ADVANCED FORMATTING	109
Concatenation	110
Advanced Formatting	113
RADIO PARAMETERS	128
Radio Protocol Timeout	129
Power-Off Timeout	129
Transmission Mode	130
Beeper Control for Radio Response	131
Battery Type	131
Single Store	132
Batch Mode	133
DISPLAY PARAMETERS	134
Date and Time	135
Contrast	135
Font Size	136
Backlight	136
Display-Off Timeout	136
Display Mode	137
Keypad	137
5 REFERENCES	138
5.1 RS232 Parameters	138
5.1.1 Handshaking	138
5.1.2 ACK/NACK Protocol	139
5.1.3 FIFO	140
5.1.4 RX Timeout	141
5.2 Pen Parameters	141
5.2.1 Minimum Output Pulse	141
5.2.2 Conversion to Code 39 and Code 128	141
5.2.3 Overflow	142
5.2.4 Output and Idle Levels	142
5.2.5 Inter-Block Delay	143
5.3 Network parameters	143
5.3.1 Slave Address Range First/Last	143
5.3.2 Warning Message	143
5.3.3 Master Header/Terminator Selection	144
5.4 Data Format	144

5.4.1	Header/Terminator Selection	144
5.4.2	Set Custom Extended Header/Terminator Keys	146
5.4.3	Address Stamping.....	148
5.4.4	Address Delimiter.....	148
5.4.5	Time Stamping Format.....	148
5.4.6	Time Stamping Delimiter.....	148
5.5	Power Save.....	149
5.5.1	Sleep State	149
5.5.2	Enter Sleep Timeout	149
5.6	Reading Parameters	149
5.6.1	Trigger Signal.....	149
5.6.2	Trigger-Off Timeout.....	149
5.6.3	Reads per Cycle	150
5.6.4	Safety Time.....	150
5.7	Decoding Parameters	151
5.7.1	Ink-Spread	151
5.7.2	Overflow Control	151
5.7.3	Interdigit Control.....	151
5.8	Radio Parameters (M Series Only)	151
5.8.1	Radio Protocol Timeout.....	151
5.8.2	Power-Off Timeout.....	152
5.8.3	Transmission Mode.....	152
5.8.4	Beeper Control for Radio Response	153
5.8.5	Single Store	153
5.8.6	Batch Mode.....	154
5.9	Display Parameters (Some M Series Models Only)	155
5.9.1	Display Mode	155
5.10	Configuration Editing Commands	156
5.11	Configuration Copying Commands	157
5.11.1	Copy DRAGON™ D-Series	157
5.11.2	Copy DRAGON™ M-Series.....	158
5.11.3	Copy OM-DRAGON™	159
5.12	C-DRAGON™ Configuration.....	160
6	MESSAGE FORMATTING	161
6.1	Messages from Host to Gun	161
6.1.1	Cursor Control.....	162
6.1.2	Font Selection	163
6.1.3	Clearing Display.....	163
6.1.4	LED and Beeper Control.....	164
6.1.5	Setting RTC	164
6.2	Messages From Gun Command Keys	165
7	TECHNICAL FEATURES	166
7.1	Dragon™ D.....	166
7.2	Dragon™ M.....	167

7.3	OM-DRAGON™ / C-DRAGON™	168
7.4	System and Radio Features.....	169
7.5	Status Indicators	169
7.6	Reading Diagrams	171
A	HOST CONFIGURATION STRINGS	173
B	CODE IDENTIFIER TABLE.....	186
C	HEX AND NUMERIC TABLE	189

GENERAL VIEW

DRAGON™ D/M READERS



Figure A – DRAGON™ D and M Series Readers



Figure B – DRAGON™ M Series Readers with Display

OM-DRAGON™ / C-DRAGON™ CRADLES

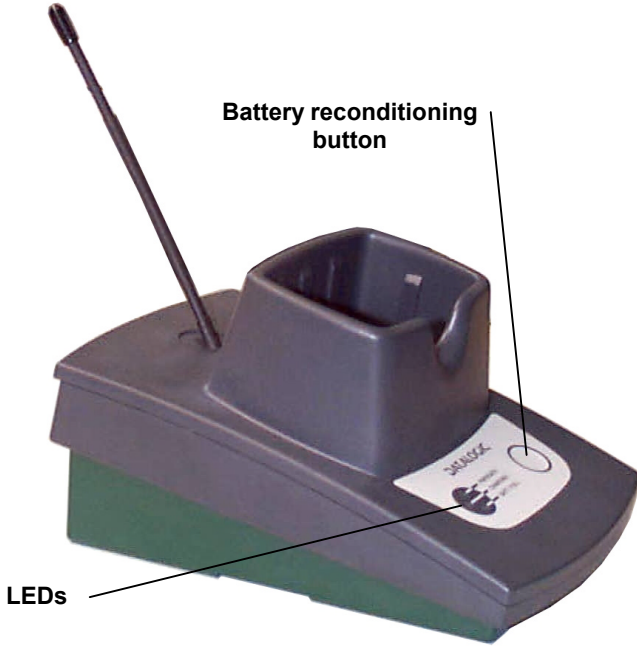

Figure C – OM-DRAGON™

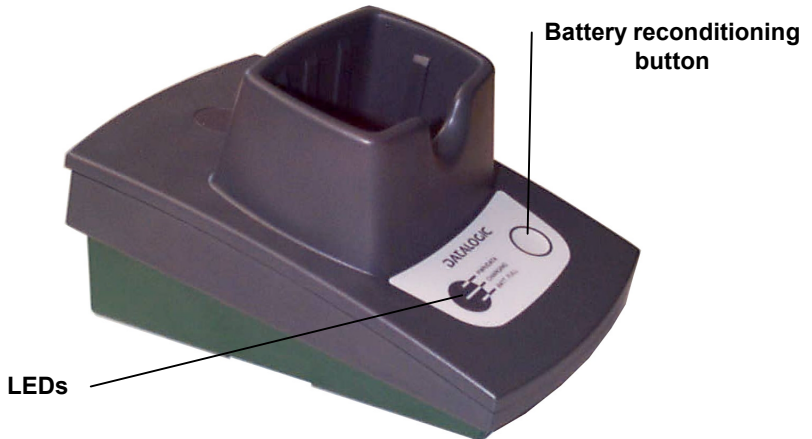

Figure D – C-DRAGON™

1 INTRODUCTION

Datalogic renews its range of industrial laser scanners introducing the **Dragon™** family: **Dragon™ Desk** and **Dragon™ Mobile**. Based on the same rugged and reliable mechanics of the well-established DLL6000 series, they have been completely renewed inside. Robustness and ergonomics, the main objective of our original project, remain unsurpassed: clearly audible beeper and bright "good read" LEDs for areas where noise levels are normally high; the aim mode, which helps point to the right code, has now been extended to the whole **Dragon™** family. Optical parts are completely suspended on shock absorbers and a careful choice of the body materials, such as the co-moulded rubber, protect the **Dragon™** from damage due to "falls".

New enhanced architecture, based on an M16 high-speed microprocessor, enables exceptional performance for promptness and reading speed of standard codes as well as the ability to read poorly printed and damaged codes. Puzzle Solver Technology™, a patent from Datalogic, adds further strength to the **Dragon™** powerful engine.

In all applications where mobility is a value, the new **Dragon™ M** represents the key to increase productivity and flexibility in the working area. **Dragon™ M** communicates through a low power, licence free radio in the 433 MHz band (910 MHz for USA version) and allows bi-directional communication between the base station and the host. **Dragon™ M** also includes a display and a 3 push-button keypad. Thanks to these features, the operator can receive information from the host, interact with the central system and visualise the code read. The cordless system offers scalable solutions to solve simple applications and complex projects:

- Point to point: each gun is associated with its own base station;
- Multipoint: up to 32 guns transmit data to one base station;
- Network: to cover a wide area, connecting up to 16 bases and 512 guns simultaneously working in automatic roaming.

Dragon™ M is 100% compatible with STAR-System™, the new Datalogic RF narrow band solution for mobile applications that provides the widest family of narrow band devices on the market.

Your **Dragon™** reader is supplied with its own Quick Reference Manual which provides connection diagrams, reading diagrams, basic application parameter settings, default values, and specific technical features. You can use either your reader's Quick Reference Manual or this Manual for initial configuration in order to set the default values and select the interface for your application. This manual provides all the necessary information for complete mechanical installation and system software configuration.

2 INSTALLATION



CAUTION

Connections should always be made with power OFF!

2.1 DRAGON™ D INTERFACE CABLE CONNECTIONS

The DRAGON™ D reader incorporates a multi-standard interface which can be connected to a Host by plugging an RS232, Wedge or Pen emulation cable into the connector and closing the cable cover as shown below.

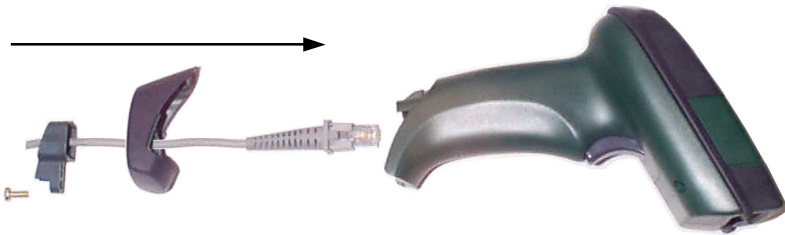

To disconnect the cable, unscrew the cover screw, pull down on the front part of the cover and insert a paper clip or other similar object onto the cable connector while unplugging the cable from the DRAGON™ D body.



 CAUTION	<p><i>Connections should always be made with power OFF!</i></p>
---	---

2.2 OM-DRAGON™ INTERFACE CABLE CONNECTIONS

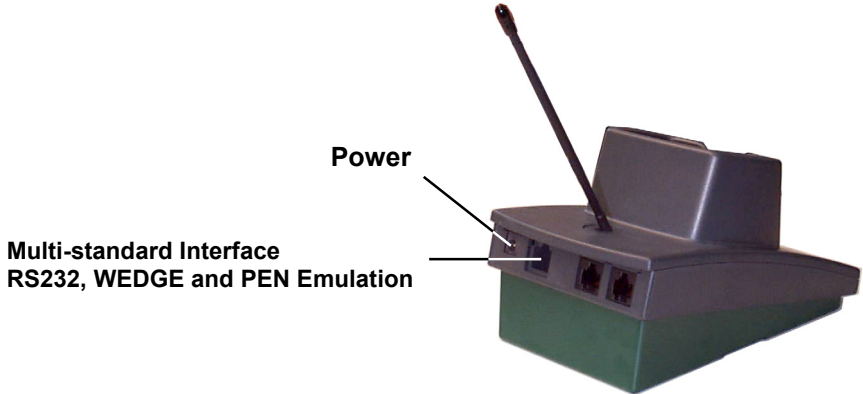

OM-DRAGON™ connectors

The OM-DRAGON™ incorporates a multi-standard interface which can be connected to a Host by simply plugging an RS232, Wedge or Pen emulation cable into the Host connector, visible on the rear panel of the cradle.

To disconnect the cable, insert a paper clip or other similar object into the hole corresponding to the Host connector on the body of the cradle.

Push down on the clip while unplugging the cable.



2.3 RS232 CONNECTION

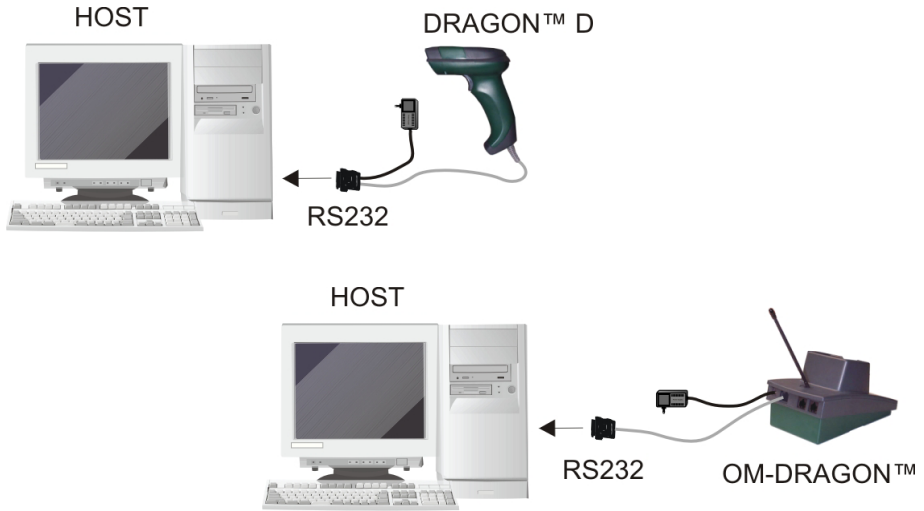

2.4 WEDGE CONNECTION

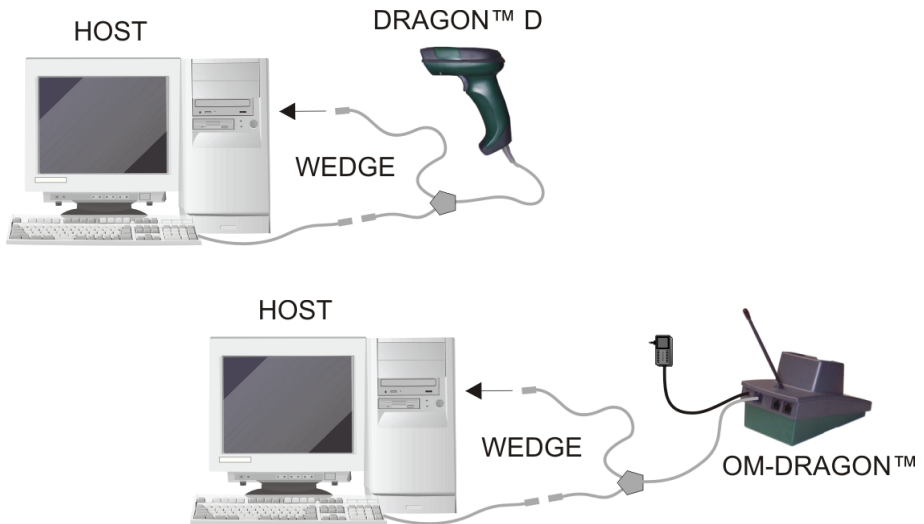

2.5 PEN EMULATION CONNECTION

CASH REGISTER

DRAGON™ D

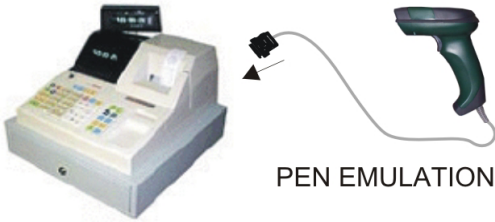

CASH REGISTER

OM-DRAGON™

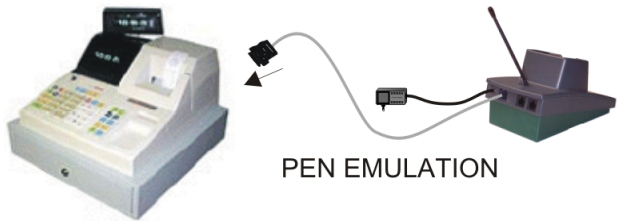

2.6 NETWORK CONNECTIONS

2.6.1 OM-DRAGON™ Network Connectors

The multidrop network is a bus system which is propagated from one cradle to another using individual cables. This is possible thanks to the two RS485 connectors on the rear panel of the cradle.

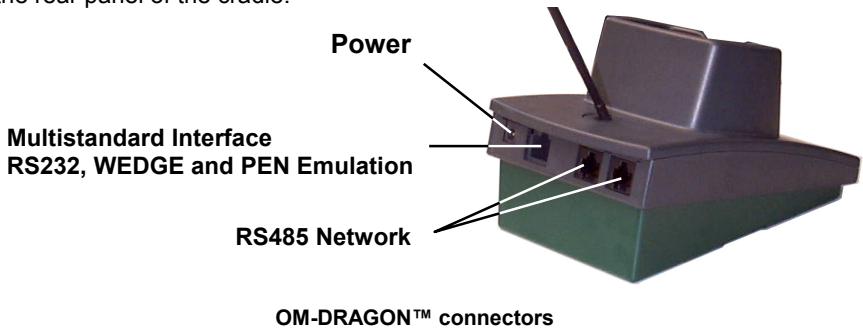

The two RS485 connectors are identical in every respect so that the point-to-point cables can be chained together without limitations concerning the bus wiring. Obviously cable length is to be kept to a minimum as with all bus systems.

2.6.2 Network Cabling

The Multidrop line is made using RJ45 connectors and a cable having the following specifications:

- twisted pair AWG 24 wires
- 120 Ω impedance
- maximum network cable length 1200 meters

Pin	Function
1	RS485 +
2	RS485 -
3	N.C.
4	VDC -
5	VDC -
6	N.C.
7	VDC +
8	VDC +

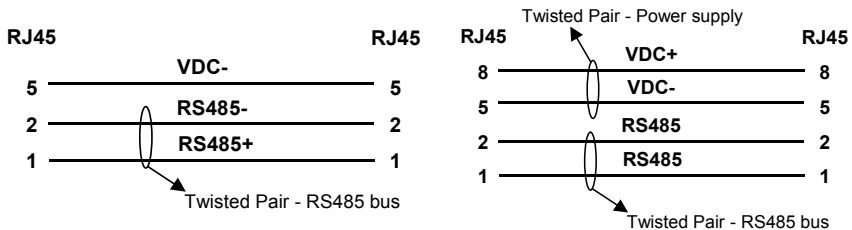
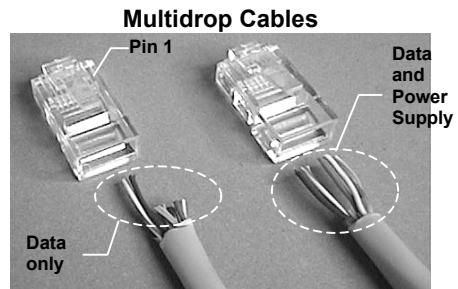

When wiring the multidrop cables, note the following:

Pin 8 (or 7) can be connected only if the power has to be propagated from a cradle to a STARGATE™ base station or STAR-Box™ converter via the cable.

Pins 5 (or 4) should always be connected as reference ground.

To avoid excessive voltage drop, it is recommended to not propagate power between OM-DRAGON™ cradles when used as battery chargers but to supply each cradle

individually. The total number of devices which can be connected to a single power supply depends on the power supply voltage, the wire length and resistance and therefore the voltage drop. Do NOT connect VDC+ between network devices that are individually powered.

2.6.3 Network Termination

The first and last cradles of the chain (the two ends of the bus) must be properly terminated. The cradle has an internal terminator that can be selected via jumper. For this selection you must open the device.

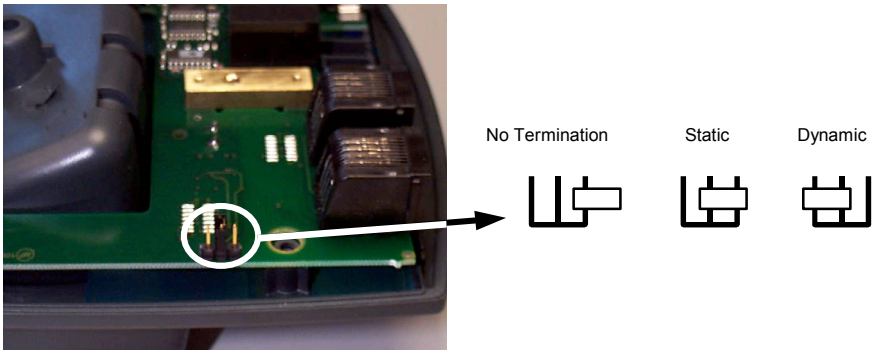

Terminator for Multidrop Network

Static termination works for all network configurations. However, the network is always under load even when no data transmission takes place.

Dynamic termination can be used for baud rates at or above 38400 and provides less load on the network when idle.

2.7 DRAGON™ M BATTERY MAINTENANCE

2.7.1 Battery Type

You can install NiMh, NiCd or Alkaline AA batteries in the DRAGON™ M.

2.7.2 Battery Charging

Once the system is connected and powered, you can place the DRAGON™ M into the cradle to charge the battery.

When the scanner is correctly inserted in the cradle, the red LED on the cradle goes on to indicate that the battery is charging. The green LED on the cradle goes on when the battery is completely charged.

When using NiCd or NiMh batteries, frequent recharging before fully discharging can cause a “memory effect” in which the batteries assume a reduced capacity.

Since it is not practical to wait for the reader to be fully discharged before recharging it, the OM-DRAGON™ and the C-DRAGON™ are provided with a battery-reconditioning feature which overcomes the “memory effect” problem.

To perform battery reconditioning, simply press the battery-reconditioning key on the cradle control panel: the battery will be fully discharged in a short period of time (red LED flashing), then automatically recharged.

We recommend performing the battery reconditioning once every few months or whenever you feel the battery capacity has decreased.

2.7.3 Replacing DRAGON™ M Batteries

To change the batteries in your DRAGON™ M scanner, proceed as follows:

1. Unscrew the battery cover screw.

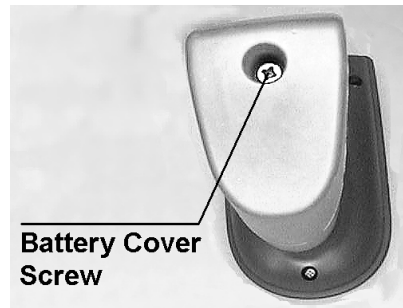

- Open the battery cover.

NOTE

When the batteries are extracted from the scanner, the timer maintains the current hour and date for about 1 minute.

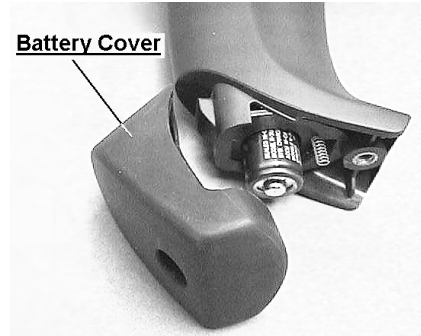

- Replace the old batteries with new ones, then screw the battery cover back into place.

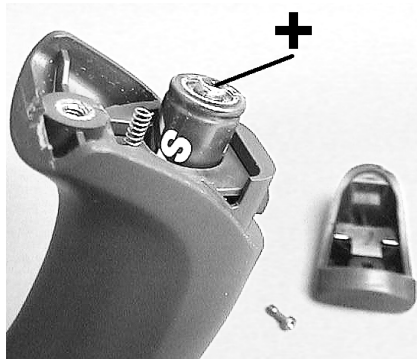

NiMh, NiCd, or Alkaline AA batteries



CAUTION

Dispose of used batteries properly.

Do not disassemble, modify, heat or throw batteries into fire. This could cause leakage of liquid, generation of heat or, in extreme cases, explosion.

Replace only with the same type recommended.

2.8 MOUNTING THE OM-DRAGON™ / C-DRAGON™ CRADLE

The cradle package contains the following devices:

OM-DRAGON™ / C-DRAGON™ Cradle with Base

OM-DRAGON™ Quick Reference / C-DRAGON™ Quick Reference

OM-DRAGON™ Antenna 2 adhesive strips

3 mounting screws 4 rubber feet

3 threaded dowels 1 alignment plate

The cradle (either OM-DRAGON™ or C-DRAGON™) can be mounted for portable or fixed desktop usage, or it can be fixed to a wall:



Desktop Use



Wall-mount Use

2.8.1 Portable Desktop Use

For desktop use, the OM-DRAGON™ is already correctly positioned onto the base.

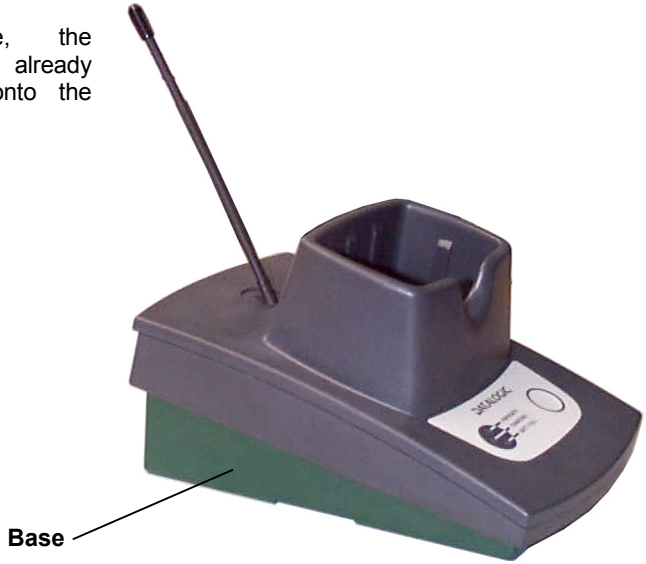

1. Carefully clean the rubber feet seat of the base to remove any impurities that could reduce adhesion.
2. Remove the protective plastic from the rubber feet and stick them onto the bottom surface of the base.

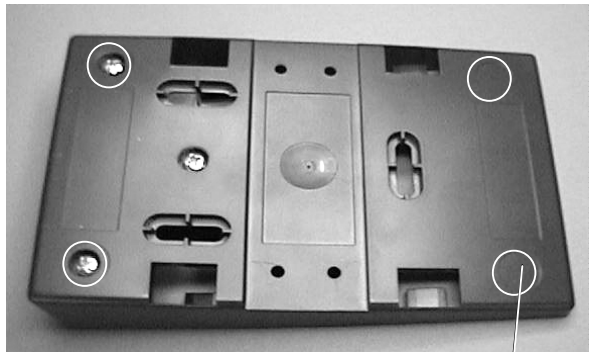

Rubber foot seat (4)

3. Insert the antenna in the appropriate hole on the body of the cradle and screw it clockwise until tight.

2.8.2 Fixed Desktop Use

For fixed desktop installation, use the adhesive strips.

1. If you are installing several cradles and you desire to align them, you can use the alignment plate (see Alignment Plate Installation), otherwise continue with step 2.

2. Carefully clean the adhesive strip seat of the base to remove any impurities that could reduce adhesion.

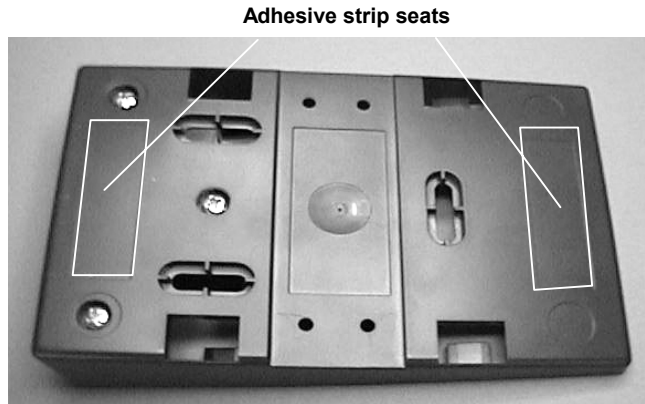

3. Remove the protective plastic from one side of the adhesive strips and stick them onto the base surface.
4. Remove the plastic from the other side of the strips and affix the base to the table.
5. Insert the antenna in the appropriate hole on the body of the cradle and screw it clockwise until tight.



2.8.3 Wall Mounting

For wall mounting, the base must be reversed 180° with respect to the cradle top. Position the base so that the thick part with the weighted plate is towards the bottom, as shown below.

1. Unscrew the cradle fixing screw and detach the cradle from the base by holding the base tight and pushing the cradle backwards.



2. If you are installing several cradles and you desire to align them, you can use the alignment plate (see Alignment Plate Installation), otherwise continue with step 3.

3. Using the mounting holes on the base as a pattern, mark the wall where you desire to mount the OM-DRAGON™.

4. Drill three appropriate size holes.

5. Insert the threaded dowels into the holes.

6. Position the base on the wall and affix it by means of the three screws.

7. Reattach the cradle body by sliding it along the mounting tabs until aligned.

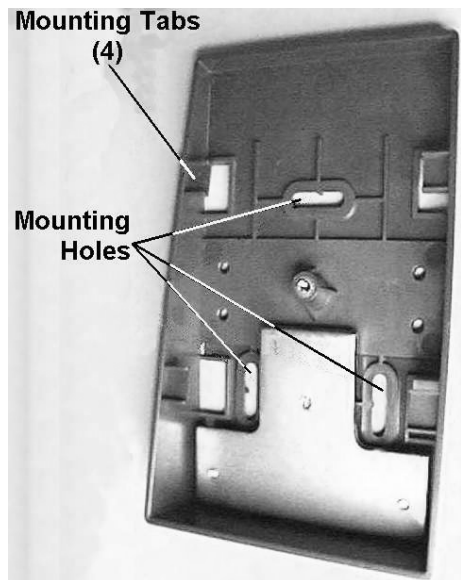

8. Fix the cradle to the base by means of the fixing screw (see above photo).

9. Insert the antenna into the appropriate hole on the body of the cradle and screw it clockwise until tight.

2.8.4 Alignment Plate Installation

1. Snap the Alignment Plate into the holes provided on the base so that the plate remains extended from the side of the base.

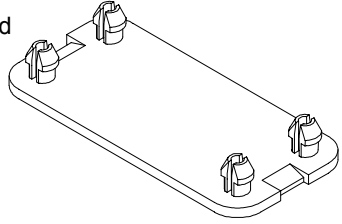

2. Snap the next base onto the remaining pins of the Alignment Plate.

Alignment Plate Holes

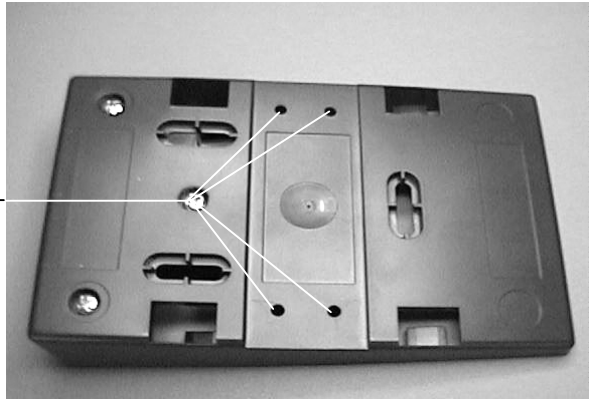

3 DRAGON™ M SYSTEM AND NETWORK LAYOUTS

There are two basic system layouts that can be employed: Stand Alone systems and Multidrop STAR-System™ Networks.

3.1 STAND ALONE LAYOUTS

3.1.1 Single Reader Layout

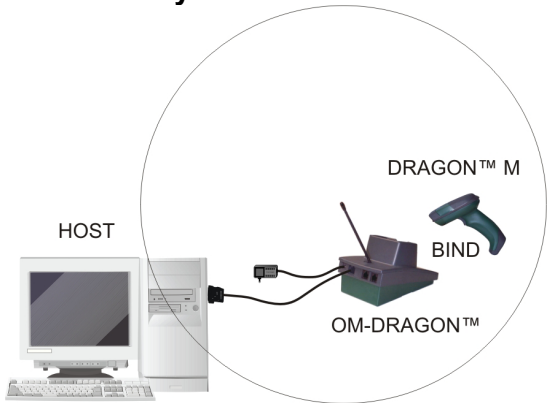

3.1.2 Multiple Reader Layout

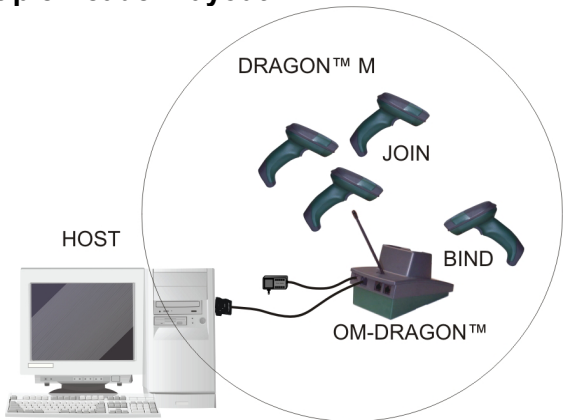

In stand alone systems, each cradle is connected to a single Host.

3.1.3 Multiple Stand Alone Layouts

Many stand alone connections can operate in the same physical area without interference, provided all readers and cradles in the system have different addresses.

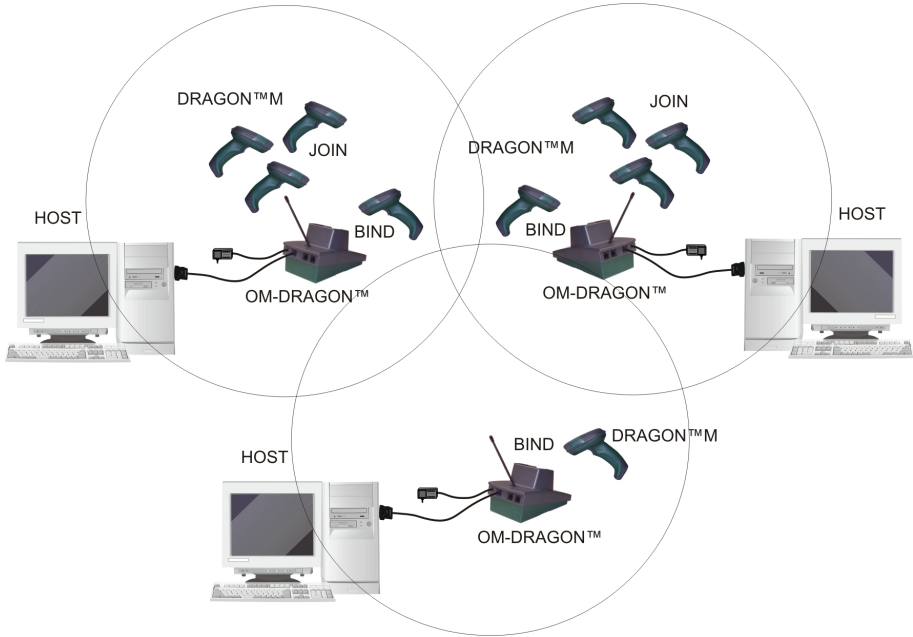

Multiple Stand Alone Systems in the Same Area

Since the cradles can communicate to multiple DRAGON™ M scanners, you might find it useful to employ one or more C-DRAGON™ battery chargers in addition to the OM-DRAGON™ cradle, so that the battery re-charging operation can be performed for several scanners at the same time.

3.1.4 C-Box Layout

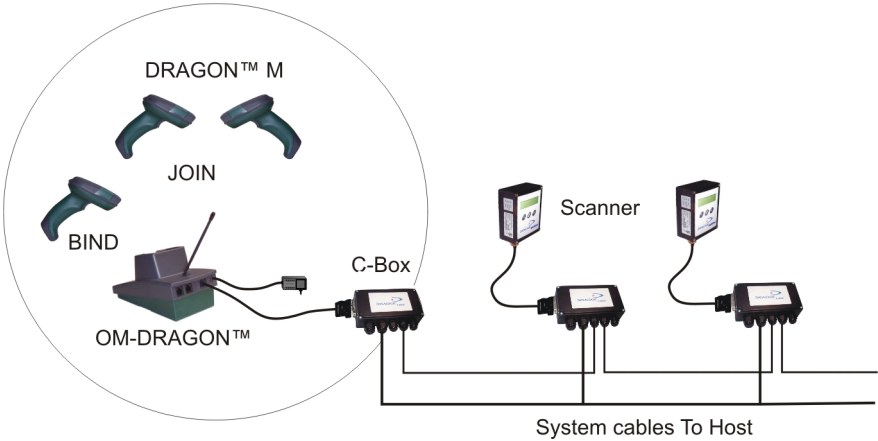

In this layout the OM-DRAGON™ cradle is connected by a dedicated cable using the RS232 interface to a C-Box connection box as part of a fixed scanner network. This allows the flexibility of a hand-held reading station integrated into a variety of fixed scanning applications so that all readers (both fixed and hand-held), in the system provide communications to the Host.

The various C-Box models provide many interface types for the Host system such as RS232, RS485, Profibus.

3.2 MULTIDROP STAR-SYSTEM™ NETWORK LAYOUTS

Even though many stand alone systems can operate in the same physical area without interfering with each other, it may be desirable to bridge data from multiple cradles in a network to a single Host. Each OM-DRAGON™ cradle is designed to connect with other cradles in order to build an RS485 Multidrop cradle network that is STAR-System™ compatible. This network provides seamless active roaming for any RF reading device in the system.

3.2.1 Host Master Layout

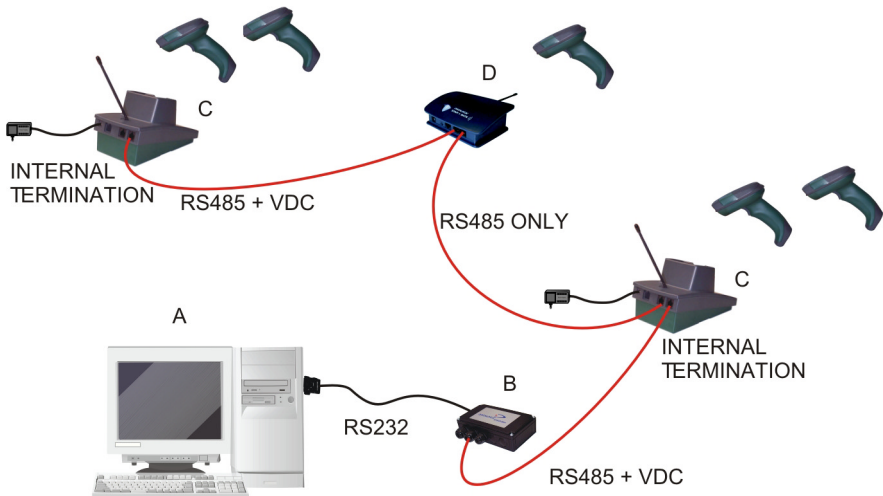

- A. Host Master with STAR-Link™
- B. STAR-Box™ converter
- C. OM-DRAGON™ Slave cradles
- D. STARGATE™ base station

Example Multidrop STAR-System™ Network with Host as Master

In this layout the Host acts as the Master using STAR-Link™ software. The Host is connected in RS232 to a STAR-Box converter which is connected to the first slave in the RS485 network. In this way the Master cradle provides communications between a single Host and all readers in the system. STARGATE™ base stations can also be used as slaves in this network. The Slaves at the ends of the network must be terminated (see par. 2.6.3).

See pars. 4.5 and 4.6 or the Sm@rtSet Help On-Line for system configuration specifications.

3.2.2 OM-DRAGON™ Master Layout

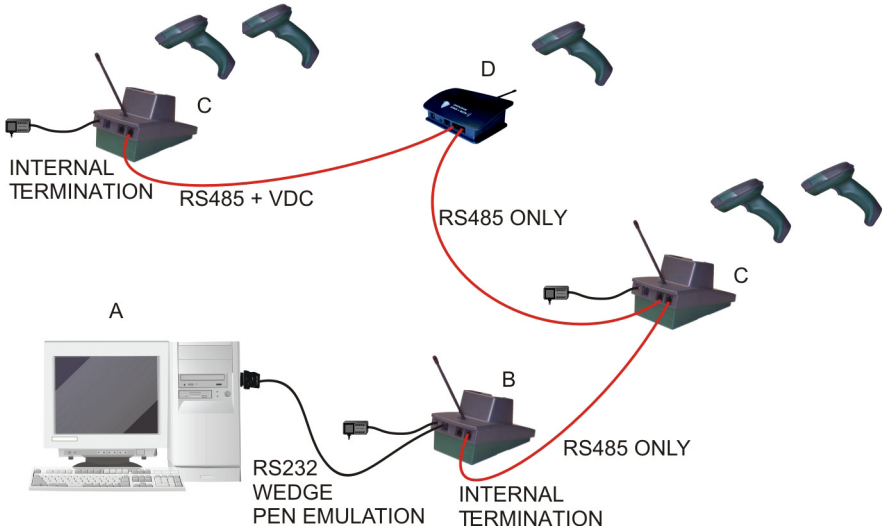

- A. Host
- B. OM-DRAGON™ Master cradle
- C. OM-DRAGON™ Slave cradles
- D. STARGATE™ base station

Example Multidrop STAR-System™ Network with OM-DRAGON™ as Master

In this layout an OM-DRAGON™ cradle acts as the Master. The Host is connected to the OM-DRAGON™ Master using any one of the multi-standard interfaces (RS232, WEDGE, or PEN Emulation). The Master is then connected to the slaves in the RS485 network. In this way the slave cradles provide communications between a single Host and all readers in the system. STARGATE™ base stations can also be used as slaves in this network. The devices at the ends of the network must be terminated (see par. 2.6.3).

See pars. 4.5 and 4.6 or the Sm@rtSet Help On-Line for system configuration specifications.

3.2.3 Master OM-DRAGON™ Network Troubleshooting

Two diagnostic strings can be sent via RS232 from the Host to the Master cradle in order to have feedback about the network itself.

#+LSlave

Returns a list of all the Slaves recognized at boot up.

Example:

In a network where the Master cradle has address **0188** and one Slave cradle with address **0001**, the response is:

```
188
  1
```

#+Alive<xxxx>

Executes a continuous Alive request to the slave xxxx in order to monitor the performance of the connection. A diagnostic message is displayed on the Host.

Example:

If this command is sent for slave cradle with address **0032**, the response is:

```
/*32: OM-DRAGON SOFTWARE RELEASE 2.00 02/10/2002*/
if there are no communication errors
```

```
/*32: FAIL*/
if there are communication errors.
```

To exit from this command, reset the system by cycling power to the Master cradle.

4 CONFIGURATION

4.1 CONFIGURATION METHODS

4.1.1 Reading Configuration Barcodes

This manual can be used for complete setup and configuration of your reader by following the setup procedures in this chapter (see par. 4.2 for an overview).

If you wish to change the default settings, this manual provides complete configuration of your reader in an easy way.

To configure your reader:

- 1) Open the folded page in [Appendix C](#) with the hex-numeric table and keep it open during the device configuration.
- 2) Read the **Enter Configuration** code ONCE, available at the top of each page of configuration.
- 3) Modify the desired parameters in one or more sections following the procedures given for each group.
- 4) Read the **Exit and Save Configuration** code ONCE, available at the top of each page of configuration.

Reference notes describing the operation of the more complex parameters are given in chapter 5.

4.1.2 Using DL Sm@rtSet

DL Sm@rtSet is a Windows-based utility program providing a quick and user-friendly configuration method via the RS232 interface.

It also allows upgrading the software of the connected device (see the DL Sm@rtSet User's Manual for more details).

4.1.3 Copy Command

A previously configured device (Master), can be used to send its configuration directly to other devices of the same type (Slaves). The particular procedure for each device is given in par. 5.11.

4.1.4 Sending Configuration Strings from Host

An alternative configuration method is provided in Appendix A using the RS232 interface. This method is particularly useful when many devices need to be configured with the same settings. Batch files containing the desired parameter settings can be prepared to configure devices quickly and easily.

4.2 SETUP PROCEDURES

For DRAGON™ D-Series readers, follow the setup procedures in pars. 4.3 and 4.7.

For DRAGON™ M-Series readers, the setup procedures depend on two basic applications, Stand Alone or STAR-System™.

Stand Alone applications allow communication with the Host by either the OM-DRAGON™ cradle (par.4.4), or by the STAR-Modem™ radio modem (par. 4.4.2).

STAR-System™ applications allow communication with the Host through an RS485 network by either the STARGATE™ RF base station or by the OM-DRAGON™ cradle (par. 4.5 and 4.6).

Proceed as shown in the following diagram:

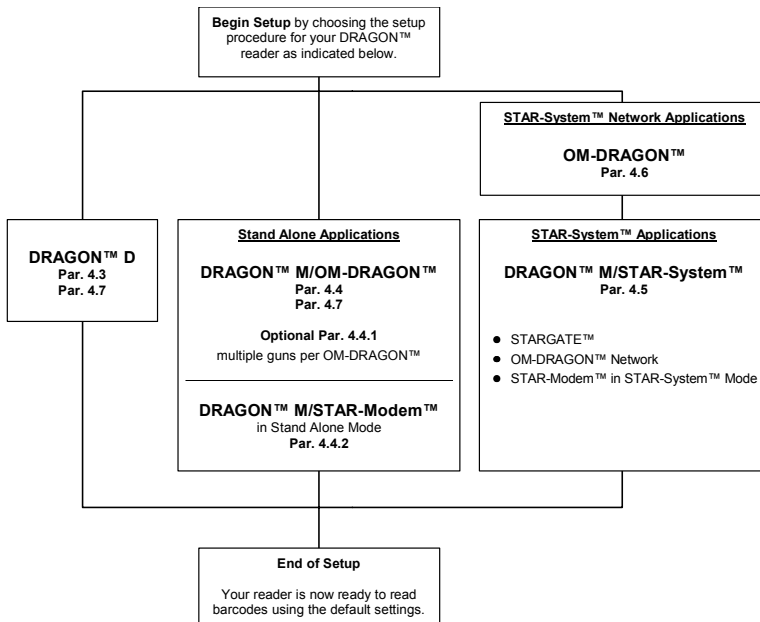

4.3 DRAGON™ D SETUP

Read the restore default parameters code below.

1.

Restore DRAGON™ D Default



After reading the above code, go to par. 4.7 Interface Selection.

4.4 DRAGON™ M/OM-DRAGON™ STAND ALONE SETUP

Read the restore default parameters code below.

1.

Restore DRAGON™ M Default



Follow the procedure below to set the radio address and bind DRAGON™ M to the OM-DRAGON cradle.

2.

Enter configuration



3.

Set Date



+

six digits for Day, Month and Year (DDMMYY)

4.

Set Time

+

four digits for Hour and Minutes (HHMM)

5.

Set Radio Address

+

four digits for the DRAGON™ M Address (from **0000** to **1999**).**All readers used in the same area must have different addresses.**

6.

Exit and Save configuration

7. Read the **Bind** code to pair the DRAGON™ M to the OM-DRAGON™ cradle. The reader is dedicated to the cradle. Any previously **bound** reader will be excluded.

To connect several readers to the same cradle see the following paragraph 4.4.1, 'Using Multiple M Series Readers with Same Cradle'.

Bind

The green LED on the DRAGON™ M will blink; the reader is ready to be inserted into the cradle.

8. Firmly insert the reader into the OM-DRAGON™ cradle within 10 seconds, a beep will be emitted, signaling that the OM-DRAGON™ cradle has been paired to the DRAGON™ M, and the green LED on the reader will go off.



9. Read the OM-DRAGON™ restore default code:

Restore OM-DRAGON™ default



Go to par. 4.7 Interface Selection.

4.4.1 Using Multiple M-Series Readers With Same Cradle

If you want to use several M-Series readers with the same OM-DRAGON™ cradle, you must first **Bind** the cradle with one of the readers (see previously described configuration procedure).

Successive readers can be associated with the same cradle by following the configuration procedure substituting the **Bind** command with **Join** (step 7).

7.

Join



The green LED on the DRAGON™ M will blink: the reader is ready to be inserted into the cradle. **Complete step 8.**

END of procedure.

**CAUTION**

If the cradle is not **Bound** to a reader, its address assumes a random value which can cause conflicts and malfunctions to other cradles within its range.

YOUR READER IS NOW READY TO READ BARCODES.

To change the defaults see par.4.8.

4.4.2 DRAGON™ M/STAR-Modem™ in Stand Alone Mode

To configure a DRAGON™ M reader to communicate with STAR-Modem™ in Stand Alone Mode, follow the procedure in par. 4.4 substituting steps 6 and 7 with those below:

6.**STAR-Modem™ Address**

Read the code above and the four-digit address of the STAR-Modem™.

7.**Exit and Save configuration****END of procedure.**

YOUR READER IS NOW READY TO READ BARCODES.

To change the defaults see par. 4.8.

4.5 DRAGON™ M/STAR-SYSTEM™ SETUP

The following procedure allows configuring a DRAGON™ M reader to communicate with various STAR-System™ devices such as STARGATE™ RF base stations.

1. **Restore DRAGON™ M Default**



2. **Enter configuration**



3. **Set Date**



+

six digits for Day, Month and Year (DDMMYY)

4. **Set Time**



+

four digits for Hour and Minutes (HHMM)

5. Set the connection according to the length of the codes to be read:

Code Length ≤240 Characters



**Code Length >240 Characters
(not for systems with OM-DRAGON™ as Master)**



Set Radio Address

6.



+

four digits from the Numeric Table in the range **0000-1999**.

All readers must have different addresses.

First STAR-System™ Address

7.



Read the code above and the four-digit address of the First STAR-System™ device in the system.

Set Last STAR-System™ Address

8.



Read the code above and the four-digit address of the Last STAR-System™ device in the system.

**NOTE**

Whenever the system is composed of a single base station, the first and last base station addresses (steps 7 and 8) must have the same value.

Exit and Save Configuration

9.



END of procedure.

YOUR READER IS NOW READY TO READ BARCODES.

To change the defaults see par. 4.8.

4.6 OM-DRAGON™ STAR-SYSTEM™ NETWORK SETUP

When the OM-DRAGON™ is used in an RS485 network, it must be initially configured. To do this using configuration barcodes, follow the procedure below using any DRAGON™ M reader.

1.

Set OM-DRAGON™ Address



+

four digits for the OM-DRAGON™ Address (from **0000** to **1999**).

All cradles used in the network must have different addresses.

2.

Exit and Save configuration



3.

Read the **Bind** code to pair the DRAGON™ M to the OM-DRAGON™ cradle for configuration.

Bind

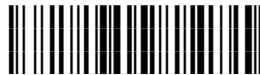

The green LED on the DRAGON™ M will blink; the reader is ready to be inserted into the cradle.

4.

Firmly insert the reader into the OM-DRAGON™ cradle within 10 seconds, a beep will be emitted, signaling that the OM-DRAGON™ cradle has been paired to the DRAGON™ M, and the green LED on the reader will go off.

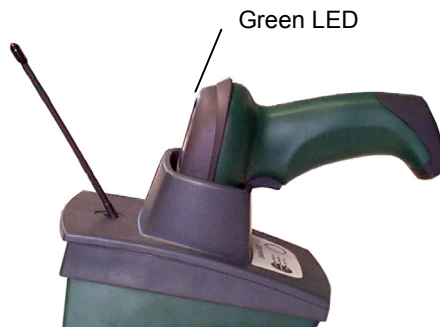

5. Read the OM-DRAGON™ restore default code:

Restore OM-DRAGON™ default



6. Read the desired Enable Network code.

Enable RS485 Master



Enable RS485 Slave



END of procedure.

For **Host Master Network Layouts** (see par. 3.2), The network configuration parameters can be changed through STAR-Link™ software running on the PC. Star-Link™ software can be downloaded for free from the Internet at the following address:

www.datalogic.com/products

and follow the links : Portable Data Collection Terminals > Software Tools

For **OM-DRAGON™ Master Network Layouts** (see par. 3.2), The network configuration parameters can be changed either through the DL Sm@rtSet™ configuration software running on the PC or by reading the barcode selections in the Network section of this manual starting on page 58. If using configuration barcodes, it is advised to completely configure the cradles before reconfiguring the DRAGON™ M reader (see below).



NOTE

After completing the OM-DRAGON™ cradle configuration and connections in the network, you must reconfigure the DRAGON™ M reader using the STAR-System™ procedure in par. 4.5.

4.7 INTERFACE SELECTION

Read the interface selection code for your application.

RS232



PEN



WEDGE

IBM AT or PS/2 PCs



IBM XT

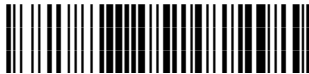

PC Notebook



WEDGE (continued)

IBM SURE1

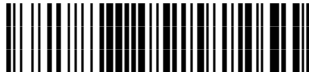

IBM Terminal 3153

**IBM Terminals 31xx, 32xx, 34xx, 37xx:**

To select the interface for these IBM Terminals, read the correct KEY TRANSMISSION code. Select the KEYBOARD TYPE if necessary (default = advanced keyboard).

KEY TRANSMISSION MODE

make-only keyboard



make-break keyboard

**KEYBOARD TYPE**

◆ advanced keyboard



typewriter keyboard



WEDGE (continued)**ALT MODE**

The ALT-mode selection allows barcodes sent to the PC to be interpreted correctly independently from the Keyboard Nationality used. **You do not need to make a Keyboard Nationality selection.**

(default = Num Lock Unchanged). **Make sure the Num Lock key on your keyboard is ON.**

IBM AT - ALT mode



PC Notebook - ALT mode

**WYSE TERMINALS**

ANSI Keyboard



PC Keyboard



ASCII Keyboard

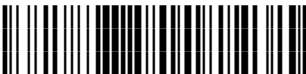

VT220 style Keyboard



WEDGE (continued)**DIGITAL TERMINALS**

VT2xx/VT3xx/VT4xx

**APPLE**

APPLE ADB Bus



4.8 CHANGING DEFAULT SETTINGS

Once your reader is setup, you can change the default parameters to meet your application needs. Refer to the preceding paragraphs for initial configuration in order to set the default values and select the interface for your application.

In this manual, the configuration parameters are divided into logical groups making it easy to find the desired function based on its reference group.

The first three groups are for Standard Interface parameter configuration for all DRAGON™ D series readers and DRAGON™ M/OM-DRAGON™ Stand Alone configurations only:

- **RS232**
- **WEDGE**
- **PEN EMULATION**

NETWORK PARAMETERS are available only for OM-DRAGON™ Network configurations.

The following parameter groups are common to all interface applications:

DATA FORMAT parameters regard the messages sent to the Host system for all interfaces except Pen Emulation.

POWER SAVE manages overall current consumption in the reading device.

READING PARAMETERS control various operating modes and indicator status functioning.

DECODING PARAMETERS maintain correct barcode decoding in certain special reading conditions.

CODE SELECTION parameters allow configuration of a personalized mix of codes, code families and their options.

ADVANCED FORMATTING PARAMETERS allow code concatenation and advanced formatting of messages towards the Host. It cannot be used with Pen Emulation connections.

RADIO PARAMETERS (M series only) allow configuration of radio control parameters.

DISPLAY PARAMETERS (some M series models only) allow configuration of reader display parameters.

RS232 PARAMETERS

All DRAGON™ D Series readers
+
DRAGON™ M/OM-DRAGON™ configurations only

⊙	BAUD RATE	⊙
⊙	PARITY	⊙
⊙	DATA BITS	⊙
⊙	STOP BITS	⊙
⊙	HANDSHAKING	⊙
⊙	ACK/NACK PROTOCOL	⊙
⊙	FIFO	⊙
⊙	INTER-CHARACTER DELAY	⊙
⊙	RX TIMEOUT	⊙
⊙	SERIAL TRIGGER LOCK	⊙
	(D-SERIES ONLY)	

1. Read the **Enter Configuration** code ONCE, available at the top of each page.
2. Read configuration codes from the desired groups.
 = Read the code and follow the procedure given
3. Read the **Exit and Save Configuration** code ONCE, available at the top of each page.

Enter configuration



Exit & Save configuration



RS232

BAUD RATE

150 baud



300 baud



600 baud



1200 baud



2400 baud



4800 baud



◆ 9600 baud



19200 baud



38400 baud





PARITY

◆ none



even parity



odd parity



DATA BITS

7 bits



◆ 8 bits



9 bits



Enter configuration



RS232

Exit & Save configuration



STOP BITS

◆ 1 stop bit



2 stop bits



HANDSHAKING

◆ disable



hardware (RTS/CTS)



software (XON/XOFF)



RTS always ON



See par. 5.1.1 for details.



ACK/NACK PROTOCOL

◆ disable



enable



See par. 5.1.2 for details, particularly on implementing this parameter with DRAGON™ M.

FIFO

disable



◆ enable



See par. 5.1.3 for details.

**RS232*****INTER-CHARACTER DELAY***

delay between characters transmitted to Host

**Read 2 numbers from the table where:**

- 00 = DELAY disabled
- 01-99 = DELAY from **1** to **99** milliseconds

◆ delay disabled

RX TIMEOUT

timeout control in reception from Host

**Read 2 numbers from the table where:**

- 00 = TIMEOUT disabled
- 01-99 = TIMEOUT from **.1** to **9.9** seconds

◆ rx timeout 5 seconds

See par. 5.1.4 for details.

Enter configuration



RS232

Exit & Save configuration



SERIAL TRIGGER LOCK (D SERIES ONLY)

◆ disable



enable and select characters



Read 2 characters from the Hex/Numeric table in the range 00-FE where:

- First character enables device trigger
- Second character inhibits device trigger until the first character is received again.

WEDGE PARAMETERS

All DRAGON™ D Series readers
+
DRAGON™ M/OM-DRAGON™ configurations only

⊙	KEYBOARD NATIONALITY	⊙
⊙	CAPS LOCK	⊙
⊙	CAPS LOCK AUTO-RECOGNITION	⊙
⊙	NUM LOCK	⊙
⊙	INTER-CHARACTER DELAY	⊙
⊙	INTER-CODE DELAY	⊙
⊙	KEYBOARD SETTING	⊙
⊙	WEDGE CONTROL CHARACTER EMULATION	⊙

1. Read the **Enter Configuration** code ONCE, available at the top of each page.

2. Read configuration codes from the desired groups.



= Read the code and follow the procedure given

3. Read the **Exit and Save Configuration** code ONCE, available at the top of each page.

Enter configuration



WEDGE

Exit & Save configuration



KEYBOARD NATIONALITY

Belgian



English



French



German



Italian



Spanish



Swedish



◆ USA



Enter configuration



WEDGE

Exit & Save configuration



Japanese



Russian (Latin)



Russian (Cyrillic)



Hungarian



Yugoslavian



Romanian



Czechoslovakian



The Japanese and Eastern Block Keyboard Nationality selections are valid only for IBM AT compatible PCs.



CAPS LOCK

◆ caps lock OFF



caps lock ON



Select the appropriate code to match your keyboard caps lock status.

Note: For **PC Notebook** interface selections, the caps lock status is automatically recognized, therefore this command is not necessary.

***CAPS LOCK
AUTO-RECOGNITION***

disable



◆ enable





NUM LOCK

toggle num lock



◆ num lock unchanged



This selection is used together with the Alt Mode interface selection for AT or Notebook PCs.

It changes the way the Alt Mode procedure is executed, therefore it should be set as follows:

- if your keyboard Num Lock is normally on use **num lock unchanged**
- if your keyboard Num Lock is normally off use **toggle num lock**

In this way the device will execute the Alt Mode procedure correctly for your application.

**WEDGE**

INTER-CHARACTER DELAY

delay between characters transmitted to Host

**Read 2 numbers from the table where:**

00 =	DELAY disabled
01-99 =	DELAY from 1 to 99 milliseconds

◆ delay disabled

INTER-CODE DELAY

delay between codes transmitted to Host

**Read 2 numbers from the table where:**

00 =	DELAY disabled
01-99 =	DELAY from 1 to 99 seconds

◆ delay disabled



WEDGE

KEYBOARD SETTING

ALPHANUMERIC KEYBOARD SETTING

The reader can be used with terminals or PCs with various keyboard types and nationalities through a simple keyboard setting procedure.

The type of computer or terminal must be selected before activating the keyboard setting command.

Keyboard setting consists of communicating to the reader how to send data corresponding to the keyboard used in the application. The keys must be set in a specific order.

Press and release a key to set it.

Some characters may require more than one key pressed simultaneously during normal use (refer to the manual of your PC or terminal for keyboard use). The exact sequence must be indicated to the reader in this case pressing and releasing the different keys.

Example:

If one has to press the "Shift" and "4" keys simultaneously on the keyboard to transmit the character "\$" to the video, to set the "\$", press and release "Shift" then press and release "4".

Each pressed and released key must generate an acoustic signal on the reader, otherwise repress the key. Never press more than one key at the same time, even if this corresponds to the normal use of your keyboard.

Press "Backspace" to correct a wrong key entry. In this case the reader emits 2 beeps.

Note: "CAPS LOCK" and "NUM LOCK" must be off before starting the keyboard setting procedure. "SHIFT" must be repressed for each character and cannot be substituted by "CAPS LOCK".

setting the alphanumeric keyboard



Read the code above.

Press the keys shown in the following table according to their numerical order.

Some ASCII characters may be missing as this depends on the type of keyboard: these are generally particular characters relative to the various national symbologies. In this case:

- **The first 4 characters (Shift, Alt, Ctrl, and Backspace) can only be substituted with keys not used, or substituted with each other.**
- characters can be substituted with other single symbols (e.g. "SPACE") even if not included in the barcode set used.
- characters can be substituted with others corresponding to your keyboard.

The reader signals the end of the procedure with 2 beeps indicating the keys have been registered.

WEDGE

01 : Shift		
02 : Alt		
03 : Ctrl		
04 : Backspace		
05 : SPACE	28 : 7	51 : N
06 : !	29 : 8	52 : O
07 : "	30 : 9	53 : P
08 : #	31 : :	54 : Q
09 : \$	32 : ;	55 : R
10 : %	33 : <	56 : S
11 : &	34 : =	57 : T
12 : '	35 : >	58 : U
13 : (36 : ?	59 : V
14 :)	37 : @	60 : W
15 : *	38 : A	61 : X
16 : +	39 : B	62 : Y
17 : ,	40 : C	63 : Z
18 : -	41 : D	64 : [
19 : .	42 : E	65 : \
20 : /	43 : F	66 :]
21 : 0	44 : G	67 : ^
22 : 1	45 : H	68 : _ (underscore)
23 : 2	46 : I	69 : `
24 : 3	47 : J	70 : {
25 : 4	48 : K	71 :
26 : 5	49 : L	72 : }
27 : 6	50 : M	73 : ~
		74 : DEL

DRAGON™ M Series Only

When working with DRAGON™ M series readers, the keyboard setup functioning is signaled by the LEDs on the OM-DRAGON™ cradle. Each key stroke corresponds to a double blinking of the green LED.

By pressing the Backspace key the red LED on the OM-DRAGON™ cradle blinks, while the green LED stays on.



CAUTION

Do not place the reader into the OM-DRAGON™ cradle during this procedure. Otherwise, the battery charging will occur modifying the LEDs functioning.

Once the procedure has been completed, the green LED turns off.

Enter configuration



WEDGE

Exit & Save configuration



CONTROL CHARACTER EMULATION

◆ Ctrl + Shift + Key



Ctrl + Key



PEN EMULATION

All DRAGON™ D Series readers
+
DRAGON™ M/OM-DRAGON™ configurations only

⊙	OPERATING MODE	⊙
⊙	MINIMUM OUTPUT PULSE	⊙
⊙	CONVERSION TO CODE 39	⊙
⊙	OVERFLOW	⊙
⊙	OUTPUT LEVEL	⊙
⊙	IDLE LEVEL	⊙
⊙	INTER-BLOCK DELAY	⊙

1. Read the **Enter Configuration** code ONCE, available at the top of each page.
2. Read configuration codes from the desired groups.
 = Read the code and follow the procedure given
3. Read the **Exit and Save Configuration** code ONCE, available at the top of each page.

PEN EMULATION

The operating mode parameters are complete commands and do not require reading the Enter and Exit configuration codes.

OPERATING MODE

◆ interpret mode



Interprets commands without sending them to the decoder.

transparent mode



Sends commands to the decoder without interpreting them.



PEN EMULATION

MINIMUM OUTPUT PULSE



See par. 5.2.1 for details.



PEN EMULATION

CONVERSION TO CODE 39 AND CODE 128

- ▶ disable conversion to Code 39



Transmits codes in their original format.

- ▣ enable conversion to Code 39



Converts codes read into Code 39 format.

- enable conversion to Code 128



Converts codes read into Code 128 format.

▶ = default value for DRAGON™ D Series readers

▣ = default value for DRAGON™ M Series readers

See par. 5.2.2 for details.



OVERFLOW

narrow



◆ medium



wide



See par. 5.2.3 for details.

OUTPUT LEVEL

◆ normal
(white = logic level 0)



inverted
(white = logic level 1)



See par. 5.2.4 for details.



PEN EMULATION

IDLE LEVEL

◆ normal
(black level)



inverted
(white level)



See par. 5.2.4 for details.

INTER-BLOCK DELAY

delay between character blocks transmitted to Host



Read 2 numbers from the table where:

00 = DELAY disabled
01-99 = DELAY from .1 to 9.9 seconds

◆ DELAY disabled

See par. 5.2.5 for details

NETWORK PARAMETERS

OM-DRAGON™ Network configurations only

⊙	<i>RS485 NETWORK</i>	⊙
⊙	<i>NETWORK BAUD RATE</i>	⊙
⊙	<i>SLAVE ADDRESS RANGE</i>	⊙
⊙	<i>WARNING MESSAGE</i>	⊙
⊙	<i>MASTER CRADLE HEADER</i>	⊙
⊙	<i>MASTER CRADLE TERMINATOR</i>	⊙

- 1.** Read the **Enter Configuration** code ONCE, available at the top of each page.
- 2.** Read configuration codes from the desired groups.
- 3.** Read the **Exit and Save Configuration** code ONCE, available at the top of each page.



RS485 NETWORK

◆ disable RS485 network



enable RS485 Slave



enable RS485 Master



See par. 3.2 for details.

**NOTE**

If an OM-DRAGON™ cradle is errantly configured as a Slave but not connected to a network, it may not be able to receive further commands from the gun. In this case it can be reconfigured by executing the bind procedure, which returns the cradle to Stand Alone configuration.

Enter configuration



Exit & Save configuration



NETWORK PARAMETERS

NETWORK BAUD RATE

9600



19200



◆ 38400



SLAVE ADDRESS RANGE

First Address



Read the code above and the four-digit address of the First Slave device in the system.

Last Address



Read the code above and the four-digit address of the Last Slave device in the system.

See par. 5.3.1 for details.



WARNING MESSAGE

◆ warning message not transmitted



warning message transmitted



See par. 5.3.2 for details.



MASTER CRADLE HEADER

◆ no header



one character header



two character header



three character header



four character header



five character header



six character header



seven character header



eight character header



After selecting **one** of the desired Header codes, read the character(s) from the HEX table.

Valid characters for all readers are in the range: **00-FE**

Example:

four character header
 + 41 + 42 + 43 + 44 = Header **ABCD**

For more details about default and WEDGE Interface Extended Keyboard values, see par. 5.3.3, 5.4.1 and 5.4.2.

**NETWORK PARAMETERS*****MASTER CRADLE TERMINATOR***

no terminator



one character terminator



two character terminator



three character terminator



four character terminator



five character terminator



six character terminator



seven character terminator



eight character terminator



After selecting **one** of the desired Terminator codes, read the character(s) from the HEX table.

Valid characters for all readers are in the range: **00-FE**

Example:

two character terminator
 + **0D** + **0A** = Terminator **CR LF**

For more details about default and WEDGE Interface Extended Keyboard values, see par. 5.3.3, 5.4.1 and 5.4.2.

DATA FORMAT

NOT FOR PEN INTERFACES

⊙	<i>CODE IDENTIFIER</i>	⊙
⊙	<i>CUSTOM CODE IDENTIFIER</i>	⊙
⊙	<i>HEADER</i>	⊙
⊙	<i>TERMINATOR</i>	⊙
⊙	<i>FIELD ADJUSTMENT</i>	⊙
⊙	<i>FIELD ADJ. CHARACTER</i>	⊙
⊙	<i>CODE LENGTH TX</i>	⊙
⊙	<i>CHARACTER REPLACEMENT</i>	⊙
⊙	<i>ADDRESS STAMPING</i>	⊙
⊙	<i>ADDRESS DELIMITER</i>	⊙
⊙	<i>TIME STAMPING</i>	⊙
⊙	<i>TIME DELIMITER</i>	⊙

1. Read the **Enter Configuration** code ONCE, available at the top of each page.

2. Read configuration codes from the desired groups.

 = Read the code and follow the procedure given

3. Read the **Exit and Save Configuration** code ONCE, available at the top of each page.

DATA FORMAT

CODE IDENTIFIER TABLE			
CODE	AIM STANDARD	DATALOGIC STANDARD	Custom
2/5 interleaved] l y	N	
2/5 industrial] X y	P	
2/5 normal 5 bars] S y	O	
2/5 matrix 3 bars] X y	Q	
EAN 8] E 4	A	
EAN 13] E 0	B	
UPC A] X y	C	
UPC E] X y	D	
EAN 8 with 2 ADD ON] E 5	J	
EAN 8 with 5 ADD ON] E 6	K	
EAN 13 with 2 ADD ON] E 1	L	
EAN 13 with 5 ADD ON] E 2	M	
UPC A with 2 ADD ON] X y	F	
UPC A with 5 ADD ON] X y	G	
UPC E with 2 ADD ON] X y	H	
UPC E with 5 ADD ON] X y	I	
Code 39] A y	V	
Code 39 Full ASCII] A y	W	
CODABAR] F y	R	
ABC CODABAR] X y	S	
Code 128] C y	T	
EAN 128] C y	k	
ISBT 128] C4	f	
Code 93] G y	U	
CIP/39] X y	Y	
CIP/HR] X y	e	
Code 32] X y	X	
MSI] M y	Z	
Plessey Standard] P 0	a	
Plessey Anker] P 1	o	
Telepen] X 0	d	
Delta IBM] X 0	c	
Code 11] H y	b	
Code 16K] K 0	p	
Code 49] T y	q	
PDF417] L 0	r	
RSS Expanded Linear and Stacked] e 0	t	
RSS Limited] e 0	v	
RSS 14 Linear and Stacked] e 0	u	

DATA FORMAT

- AIM standard identifiers are not defined for all codes: the X identifier is assigned to the code for which the standard is not defined. The y value depends on the selected options (check digit tested or not, check digit tx or not, etc.).
- Custom Code Identifiers default to Datalogic Standard.
- When customizing the Datalogic Standard code identifiers, 1 or 2 identifier characters can be defined for each code type. If only 1 identifier character is required, the second character must be selected as **FF** (disabled).
- The code identifier can be singly disabled for any code by simply selecting **FF** as the first identifier character.
- Write in the Custom character identifiers in the table above for your records.



DATA FORMAT



CODE IDENTIFIER

◆ disable



Datalogic standard



AIM standard



custom



**DATA FORMAT*****CUSTOM CODE IDENTIFIER***

define custom code identifier(s)



- ① Read the above code.
(Code Identifiers default to Datalogic Standard, see table on previous page).
- ② Select the code type from the code table in Appendix B for the identifier you want to change.
- ③ You can define 1 or 2 identifier characters for each code type. If only 1 identifier character is required, the second character must be selected as **FF** (disabled). Read the hexadecimal value corresponding to the character(s) you want to define as identifiers for the code selected in step ②: valid characters are in the range **00-FE**.

Example: To define Code 39 Code Identifier = @

Read  +  + 40 + FF

Enter configuration



DATA FORMAT

Exit & Save configuration



HEADER

no header



one character header



two character header



three character header



four character header



five character header



six character header



seven character header



eight character header



After selecting **one** of the desired Header codes, read the character(s) from the HEX table.

Valid characters for all readers are in the range: **00-FE**

Example:

four character header

 $+ 41 + 42 + 43 + 44 = \text{Header } \mathbf{ABCD}$

For more details about default and WEDGE Interface Extended Keyboard values, see par. 5.4.1 and 5.4.2.



TERMINATOR

no terminator



one character terminator



two character terminator



three character terminator



four character terminator



five character terminator



six character terminator



seven character terminator



eight character terminator



After selecting **one** of the desired Terminator codes, read the character(s) from the HEX table.

Valid characters for all readers are in the range: **00-FE**

Example:

two character terminator



+ 0D + 0A = Terminator CR LF

For more details about default and WEDGE Interface Extended Keyboard values, see par. 5.4.1 and 5.4.2.

**DATA FORMAT*****FIELD ADJUSTMENT***

◆ disable field adjustment



Field adjustment allows a number of characters n , to be added to or subtracted from the barcode read. The adjustment can be different for each enabled code type. To define the field adjustment:

- ① Read the enable field adjustment code:



enable field adjustment



- ② Select the code type from the Code Identifier Table in Appendix B.
 ③ Select the type of adjustment to perform:

right addition



left addition



right deletion



left deletion



- ④ Read a number in the range **01 - 32** from the Hex/Numeric Table to define how many characters to add or delete:

Conditions:

- Adjustment is only performed on the barcode data, the Code Identifier and Code Length Transmission fields are not modified by the field adjustment parameter.
- If the field setting would subtract more characters than exist in the barcode, the subtraction will take place only to code length 0.
- You can set up to a maximum of 10 different field adjustments on the same barcode family or on different barcode families.

Example: To add 4 characters to the right of Standard Code 39 Codes:

Read enable field adjustment + Code 39 + right addition + 04



DATA FORMAT

FIELD ADJUSTMENT CHARACTER

- ① Read the field adjustment character code:



field adjustment character



- ② Read the hexadecimal value corresponding to the character you want to use for field adjustment.

Valid characters for all readers are in the range: **00-FE**

Example:

To define the field adjustment character = **A**:

Read field adjustment character
 + 41

CODE LENGTH TX

- ◆ code length not transmitted



code length transmitted in variable-digit format



code length transmitted in fixed 4-digit format



The code length is transmitted in the message after the Headers and Code Identifier characters. The code length is *calculated* after performing any field adjustment operations.



DATA FORMAT

CHARACTER REPLACEMENT

◆ disable character replacement



This parameter allows up to three characters to be replaced from the barcode read. These substitutions are stored in memory. To define each character replacement:

- ① Read one of the following character replacement codes:



first character replacement



second character replacement



third character replacement



- ② From the Code Identifier Table in Appendix B, read the Code Identifier for the desired code family.
0 = character replacement will be effective for all code families.
- ③ From the Hex/Numeric Table read two characters corresponding to the Hex value which identifies the character to be replaced. Valid values for all readers are in the range **00-FE**.
- ④ From the Hex/Numeric Table read two characters corresponding to the Hex value which identifies the new character to replace. Valid values for all readers are in the range **00-FE**.
FF = the character to be replaced will be substituted with no character, that is, it will be removed from the code.



DATA FORMAT

Example:

The following strings define:

1. *First Character Replacement:* substitution in *Code 39 barcodes* of all occurrences of the **0** character with the **1** character.
2. *Second Character Replacement:* substitution in *Code 39 barcodes* of all occurrences of the **A** character with the **B** character.

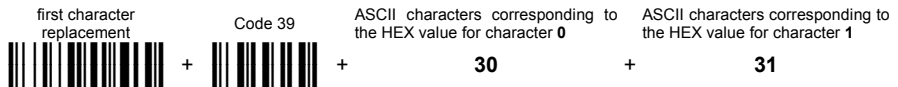

For Code 39 codes containing the string "**0**123", the contents transmitted will be "**1**123".

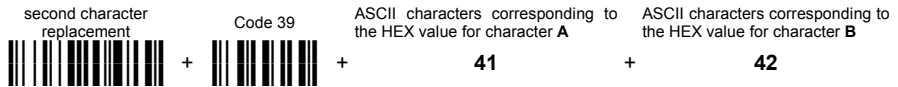

For Code 39 codes containing the string "**A**BCD", the contents transmitted will be "**B**BCD".



DATA FORMAT

ADDRESS STAMPING (M SERIES ONLY)

◆ disable reader address stamping



enable reader address stamping

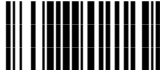

◆ disable cradle address stamping



enable cradle address stamping



See par. 5.4.3 for details.

ADDRESS DELIMITER (M SERIES ONLY)

◆ disable reader address delimiter



enable reader address delimiter and
select characters



◆ disable cradle address delimiter



enable cradle address delimiter and
select characters

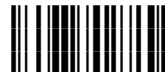

Read 2 HEX characters in the range **00-FE**.

Read 2 HEX characters in the range **00-FE**.

See par. 5.4.4 for details.

Enter configuration



Exit & Save configuration



DATA FORMAT

TIME STAMPING (M SERIES ONLY)

◆ disable



hour/minutes/seconds
month/day/year



hour/minutes/seconds
day/month/year



hour/minutes/seconds



month/day/year



day/month/year



See par. 5.4.5 for details

TIME STAMPING DELIMITER (M SERIES ONLY)

◆ disable



select delimiter



Read 2 HEX characters in the range **00-FE**.

See par. 5.4.6 for details

POWER SAVE

⊙	SLEEP STATE	⊙
⊙	ENTER SLEEP TIMEOUT	⊙

- 1.** Read the **Enter Configuration** code ONCE, available at the top of each page.
- 2.** Read configuration codes from the desired groups.
 = Read the code and follow the procedure given
- 3.** Read the **Exit and Save Configuration** code ONCE, available at the top of each page.



POWER SAVE

SLEEP STATE

◆ disable



enable



See par. 5.5.1 for details.

For M-series readers, sleep state is entered immediately after reading a code and is not configurable.

ENTER SLEEP TIMEOUT

enter sleep timeout



Read 2 numbers in the range 00-99:

- 00 = Enter Sleep state immediately
- 01-99 = corresponds to a max. 9.9 sec. delay before entering the Sleep state.

See par. 5.5.2 for details.

READING PARAMETERS

⊙	<i>TRIGGER TYPE</i>	⊙
⊙	<i>TRIGGER SIGNAL</i>	⊙
⊙	<i>TRIGGER-OFF TIMEOUT</i>	⊙
⊙	<i>FLASH MODE</i>	⊙
⊙	<i>READS PER CYCLE</i>	⊙
⊙	<i>SAFETY TIME</i>	⊙
⊙	<i>BEEPER INTENSITY</i>	⊙
⊙	<i>BEEPER TONE</i>	⊙
⊙	<i>AIMING SYSTEM</i>	⊙

1. Read the **Enter Configuration** code ONCE, available at the top of each page.
2. Read configuration codes from the desired groups.
 = Read the code and follow the procedure given
3. Read the **Exit and Save Configuration** code ONCE, available at the top of each page.

Enter configuration



Exit & Save configuration



READING PARAMETERS

TRIGGER TYPE

◆ hardware trigger



Restores TRIGGER MODE

software trigger



Enables FLASH MODE

TRIGGER SIGNAL

◆ trigger active level



trigger active pulse



See par. 5.6.1 for details.



READING PARAMETERS

TRIGGER-OFF TIMEOUT



trigger-off timeout



Read 2 numbers in the range 00-99:

00 = disables the trigger-off timeout

01-99 = corresponds to a max. 99 sec. delay after the trigger press to allow the reader to turn off automatically.

- ◆ trigger-off timeout disabled

See par. 5.6.2 for details.

FLASH MODE



"FLASH" ON duration



"FLASH" OFF duration



Read 2 numbers in the range 01-99:

01 to 99 = from .1 to 9.9 seconds.

- ◆ Flash-ON = 1 sec. Flash-OFF = 0.6 sec



READING PARAMETERS

READS PER CYCLE

◆ one read per cycle



multiple reads per cycle



See par. 5.6.3 for details.

SAFETY TIME



safety time



Limits same code consecutive reading.

Read 2 numbers in the range 00-99:

00 = no same code consecutive reading until reader is removed (no decoding) for at least 400 ms.

01 to 99 = timeout from .1 to 9.9 seconds before a consecutive read on same code.

◆ safety time = 0.5 sec

See par. 5.6.4 for details.

**READING PARAMETERS*****BEEPER INTENSITY***

* very low intensity



low intensity



medium intensity



◆ high intensity



- * This sets the beeper OFF for data entry, while for all other beeper signals it has the meaning very low intensity.

The Intensity parameter is effective for all operating conditions described in par. 7.5.

BEEPER TONE

tone 1



◆ tone 2



tone 3



tone 4



Enter configuration



READING PARAMETERS

Exit & Save configuration



AIMING SYSTEM

◆ disabled



300 ms



500 ms



1 sec



DECODING PARAMETERS

⊙	INK-SPREAD	⊙
⊙	OVERFLOW CONTROL	⊙
⊙	INTERDIGIT CONTROL	⊙
⊙	DECODING SAFETY	⊙
⊙	PUZZLE SOLVER™	⊙



CAUTION

Before changing these parameter values read the descriptions in par. 5.7.

- 1.** Read the **Enter Configuration** code ONCE, available at the top of each page.
- 2.** Read configuration codes from the desired groups.
- 3.** Read the **Exit and Save Configuration** code ONCE, available at the top of each page.



INK-SPREAD

disable



◆ enable



See par. 5.7.1 for details.

OVERFLOW CONTROL

disable



◆ enable



See par. 5.7.2 for details.



DECODING PARAMETERS



INTERDIGIT CONTROL

disable



◆ enable



See par. 5.7.3 for details.

DECODING SAFETY

◆ one read



(decoding safety disabled)

three reads



two reads

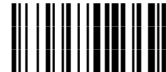

four reads



Required number of good reads before accepting code.



PUZZLE SOLVER™

◆ disable



enable



In the case of damaged or poorly printed codes, this parameter allows reading multiple parts of the single code to reconstruct it.

To read codes using this technology, simply move the illuminated bar over the code so that each line of the code is scanned. During this process a series of brief "ticks" indicates that reading is proceeding correctly.

Conditions:

- This parameter is only valid for the following codes:

EAN 8 without Add-on	EAN 13 without Add-on	UPC A without Add-on
Code 128	Code 39	

- Codablock-A and Codablock-F codes are automatically disabled.
- For Code 39, Check digit control without transmission is forced.
- PuzzleSolver™ is disabled when code ISBT 128 is enabled.

CODE SELECTION

⊙	<i>EAN/UPC FAMILY</i>	⊙
⊙	<i>2/5 FAMILY</i>	⊙
⊙	<i>CODE 39 FAMILY</i>	⊙
⊙	<i>CODE 128 FAMILY</i>	⊙
⊙	<i>CODABAR FAMILY</i>	⊙
⊙	<i>CODE 93</i>	⊙
⊙	<i>MSI</i>	⊙
⊙	<i>PLESSEY</i>	⊙
⊙	<i>TELEPEN</i>	⊙
⊙	<i>DELTA IBM</i>	⊙
⊙	<i>CODE 11</i>	⊙
⊙	<i>CODE 16K</i>	⊙
⊙	<i>CODE 49</i>	⊙
⊙	<i>RSS CODES</i>	⊙

- 1.** Read the **Enter Configuration** code ONCE, available at the top of each page.
- 2.** Read configuration codes from the desired groups.
 = Read the code and follow the procedure given
- 3.** Read the **Exit and Save Configuration** code ONCE, available at the top of each page.

**CODE SELECTION**

DISABLE ALL CODE FAMILIES

**NOTE**

The reader allows up to 5 code selections. This does not limit the number of CODES enabled to 5, as it depends on the code family.

SINGLE SELECTIONS =

- **ONE** combination code from the EAN family
- **ONE** code from the 2/5 family

Example

5 code selections:

1. **2/5 Interleaved**
2. **2/5 Industrial**
3. Code 128 + EAN 128
4. Code 39 Full ASCII + Code 32
5. **UPC A/UPC E**

In this section all **SINGLE** code selections are **underlined and in bold.**

**CODE SELECTION*****EAN/UPC FAMILY***

disable the family



- ① Read the desired family code

Note:

Since the EAN/UPC without ADD ON code selection is enabled by default, to correctly enable another selection, first disable the family.

EAN 8/EAN 13/UPC A/UPC E with and without ADD ON**WITHOUT ADD ON****◆ EAN 8/EAN 13/UPC A/UPC E****EAN 8/EAN 13****UPC A/UPC E**

Enter configuration



Exit & Save configuration



CODE SELECTION

WITH ADD ON 2 AND 5

EAN 8/EAN 13/UPC A/UPC E



EAN 8/EAN 13

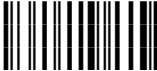

UPC A/UPC E



WITH ADD ON 2 ONLY

EAN 8/EAN 13



UPC A/UPC E



WITH ADD ON 5 ONLY

EAN 8/EAN 13



UPC A/UPC E





CODE SELECTION

EAN/UPC CHECK DIGIT TX SELECTIONS

For each code type in this family you can choose to transmit the check digit or not

CHECK DIGIT TRANSMISSION

EAN 8



EAN 13



UPC A



UPC E



NO CHECK DIGIT TRANSMISSION

EAN 8



EAN 13



UPC A



UPC E





CODE SELECTION

CONVERSION OPTIONS

UPC E to UPC A conversion



UPC E to EAN 13 conversion



UPC A to EAN 13 conversion



EAN 8 to EAN 13 conversion



enable only ISBN conversion



enable only ISSN conversion

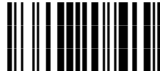

enable both ISBN and ISSN conversion



disable both ISBN and ISSN conversion

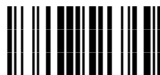

**CODE SELECTION****2/5 FAMILY**

disable the family



① Read the desired family code

◆ **Interleaved 2/5**◆ **Normal 2/5 (5 Bars)**◆ **Industrial 2/5 (IATA)**◆ **Matrix 2/5 (3 Bars)**

② Read a check digit selection

CHECK DIGIT TABLE

no check digit control



◆ check digit control and transmission



Check digit control without transmission

③ Read **4** numbers for the code length where:

- **First 2 digits** = minimum code length.
- **Second 2 digits** = maximum code length.

The maximum code length is 99 characters.

The minimum code length must always be less than or equal to the maximum.

Examples:

0199 = variable from 1 to 99 digits in the code.**1010** = 10 digit code length only.

The pharmaceutical code below is part of the 2/5 family but has no check digit nor code length selections.

Code CIP/HR

French pharmaceutical code

Enter configuration



Exit & Save configuration



CODE SELECTION

CODE 39 FAMILY

disable the family



① Read the desired family code

② Read a check digit selection

CHECK DIGIT TABLE

◆ Standard Code 39



◆ Full ASCII Code 39



◆ no check digit control



check digit control
and transmission



check digit control
without transmission





CODE SELECTION

The pharmaceutical codes below are part of the Code 39 family but have no check digit selections.

Code CIP39



French pharmaceutical code

Code 32



Italian pharmaceutical code

CODE LENGTH (optional)

The code length selection is valid for the entire Code 39 family

Read the code + 4 numbers for the code length where:

First 2 digits = minimum code length.

Second 2 digits = maximum code length.

set code length



The maximum code length is 99 characters. The minimum code length must always be less than or equal to the maximum.

Examples: **0199** = variable from 1 to 99 digits in the code. **1010** = 10 digit code length only.

**CODE SELECTION*****CODE 128 FAMILY***

disable the family



- ① Read the desired family code

◆ **Code 128**control without transmission
of check digit**EAN 128**control without transmission
of check digit**Transmit GS Before Code**

Code EAN 128 uses the ASCII <GS> character to separate a variable length code field from the next code field. This character can also be transmitted before the code.

◆ **disable****enable**

If the <GS> character has been modified in the Character Replacement parameter, the new character is affected by this command.



CODE SELECTION

ISBT 128



Enabling ISBT 128 automatically disables Puzzle Solver™.

CODE LENGTH (optional)

The code length selection is valid for the entire Code 128 family

Read the code + 4 numbers for the code length where:

First 2 digits = minimum code length.

Second 2 digits = maximum code length.

set code length



The maximum code length is 99 characters. The minimum code length must always be less than or equal to the maximum.

Examples: **0199** = variable from 1 to 99 digits in the code. **1010** = 10 digit code length only.

The length is calculated on the output string

CODE 93

◆ disable the code



Code 93



control without transmission
of check digit



CODE SELECTION

CODABAR FAMILY

◆ disable the family



① Read the desired equality control code

② Read a start/stop transmission selection

Standard Codabar



no start/stop character equality control

START/STOP CHARACTER TRANSMISSION

no transmission



Standard Codabar



start/stop character equality control

transmission



The Codabar ABC code below uses a fixed start/stop transmission selection.

Codabar ABC



no start/stop character equality control but transmission.



CODE SELECTION

Codabar ABC Forced Concatenation

enable Codabar ABC with forced concatenation



non start/stop character equality control but transmission

CODE LENGTH (optional)

The code length selection is valid for the entire Codabar family

Read the code + 4 numbers for the code length where:

First 2 digits = minimum code length.

Second 2 digits = maximum code length.

set code length



The maximum code length is 99 characters. The minimum code length must always be less than or equal to the maximum.

Examples: **0199** = variable from 1 to 99 digits in the code. **1010** = 10 digit code length only.

START/STOP CHARACTER CASE IN TRANSMISSION

The start/stop character case selections below are valid for the entire Codabar family:

transmit start/stop characters in lower case



transmit start/stop characters in upper case





CODE SELECTION

MSI

◆ disable the family



Enable the code by selecting one of the check digit selections.

no check digit control



MOD10 check digit control
no check digit transmission



MOD10 check digit control
check digit transmission



MOD11 - MOD10 check digit control
no check digit transmission



MOD11 - MOD10 check digit control
check digit transmission



MOD10 - MOD10 check digit control
no check digit transmission



MOD10 - MOD10 check digit control
check digit transmission



Enter configuration



Exit & Save configuration



CODE SELECTION

PLESSEY

◆ disable the family



Enable the code by selecting one of the check digit selections.

Standard Plessey

no check digit control



check digit control
check digit transmitted

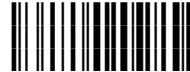

check digit control
check digit not transmitted



Anker Plessey

no check digit control



check digit control
check digit transmitted



check digit control
check digit not transmitted



Enter configuration



Exit & Save configuration



CODE SELECTION

TELEPEN

◆ disable the family



Enable the code by selecting one of the check digit selections.

Numeric Telepen

no check digit control



check digit control
check digit transmitted



check digit control
check digit not transmitted



Alphanumeric Telepen

no check digit control



check digit control
check digit transmitted



check digit control
check digit not transmitted





CODE SELECTION



DELTA IBM

◆ disable the family



Enable the code by selecting one of the check digit selections.

no check digit control



Type 1 check digit control



Type 2 check digit control



Enter configuration



CODE SELECTION

Exit & Save configuration



CODE 11

◆ disable the family



Enable the code by selecting one of the check digit selections.

no check digit control



Type C check digit control
check digit transmitted



Type C check digit control
check digit not transmitted



Type K check digit control
check digit transmitted



Type K check digit control
check digit not transmitted



Type C and Type K
check digit control
check digits transmitted



Type C and Type K
check digit control
check digits not transmitted





CODE SELECTION

CODE 16K

◆ disable the code



Code 16K



To read stacked codes, simply move the illuminated bar over the code so that each line of the code is scanned. During this process a series of brief "ticks" indicates that reading is proceeding correctly.

CODE 49

◆ disable the code



Code 49



To read stacked codes, simply move the illuminated bar over the code so that each line of the code is scanned. During this process a series of brief "ticks" indicates that reading is proceeding correctly.



CODE SELECTION

RSS CODES

◆ disables the family



DISABLE CODE

disable RSS Expanded Linear and Stacked



disable RSS Limited



disable RSS 14 Linear and Stacked



ENABLE CODE

enable RSS Expanded Linear and Stacked



enable RSS Limited



enable RSS 14 Linear and Stacked



ADVANCED FORMATTING

NOT FOR PEN INTERFACES

- ⊙ **CONCATENATION** ⊙
- ⊙ **ADVANCED FORMATTING** ⊙



NOTE

Please follow the setup procedure carefully for these parameters.

- 1.** Read the **Enter Configuration** code ONCE, available at the top of page .
- 2.** Read configuration codes **precisely following the numbered procedure given.**
 = Read the code and follow the procedure given
- 3.** Read the **Exit and Save Configuration** code ONCE, available at the top of page.



ADVANCED FORMATTING

CONCATENATION

◆ disable



enable



Permits the concatenation of two codes defined by code type and length. It is possible to set a timeout for the second code reading and to define code transmission if the timeout expires.

The order of transmission is CODE 1-CODE 2.

Define Concatenation

1

Code 1

code ID



Read the code type from the Code Identifier Table beginning in Appendix B.

code length



Read a number in the range **01-99** from the Hex/Numeric Table.

ADVANCED FORMATTING



2

Code 2

code ID



Read the code type from the Code Identifier Table beginning in Appendix B.

Code length



Read a number in the range **01-99** from the Hex/Numeric Table.

3

Concatenation Result Code ID

use code 1 ID

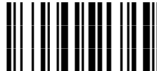

use code 2 ID



Since you can concatenate codes from different families, you must select the Code ID character of the resulting code. The Code ID character will be sent in the output message only if it is enabled according to the Code Identifier selection (Datalogic, AIM, or Custom).

4

Concatenation Timeout

timeout



Read two numbers in the range **00 to 99**

00= no timeout

01-99 = timeout from 1 to 99 seconds

Define the timeout, which determines the valid waiting period between the two codes, in order to accept concatenation. If the timeout expires, the resulting action will be based on the following selection.



ADVANCED FORMATTING

5

Transmission after Timeout

no code transmitted
after timeout



only code 1 transmitted
(if read) after timeout



only code 2 transmitted
(if read) after timeout



either code 1 or code 2 transmitted
after timeout



ADVANCED FORMATTING

ADVANCED FORMATTING

Advanced formatting has been designed to offer you complete flexibility in changing the format of barcode data **before** transmitting it to the host system. This formatting will be performed when the barcode data meets certain criteria which you will define in the following procedure.

Up to 4 advanced code management formats can be defined and saved in memory. For each format you must complete the entire configuration procedure:

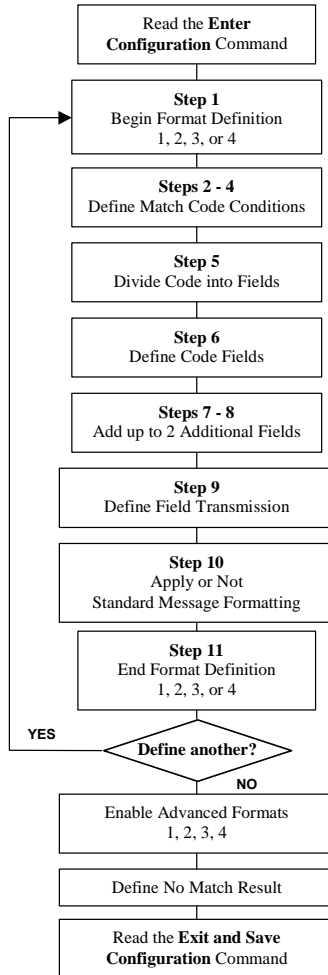



ADVANCED FORMATTING

1

Begin Format Definition

begin Format 1 definition



begin Format 2 definition



begin Format 3 definition



begin Format 4 definition



2

Match Code Type

match code type



Read the above code + the code type to match from the Code Identifier Table in Appendix B.

OR

any code type



3

Match Code Length

match code length



Read the above code + two numbers in the range **01** to **99** for the exact code length.

OR

any code length





ADVANCED FORMATTING

4

Match with Predefined Characters

no match



OR

match with 1 character



match with a 2-character string



match with a 3-character string



match with a 4-character string



After selecting the predefined match code, read the character(s) from the HEX table. Range of characters = **01-FE**.

Example:

Match code with the 2-character predefined string = "@@".

Read  + 40 + 40

AND

position of first character in predefined string



Read the above code + two numbers in the range **01** to **99** representing the character position in the code where the first character of the predefined string must be found.

Read **00** if the match string can be found in any character position.



ADVANCED FORMATTING

5

Divide Code into Fields

divide code into fields



Read one number in the range **1** to **5** to divide the code into fields.

6

Define Code Fields

define code fields

Each code field length can be set by either:

- a) defining a field separator character to be found in the code itself. In this case you can choose to **discard** the code separator character or **include** it as the last character of the field.

OR BY

- b) specifying a specific character length up to the maximum of 99 characters.

OR BY



- c) selecting the last field as variable length (if any).

You must define the same number of fields as selected in step 5, including fields that will not be transmitted.





ADVANCED FORMATTING

DEFINE FIELD 1 BY: EITHER



a)  field separator

Read the field separator character from the HEX table. Range of characters = **01-FE**.

discard separator

include separator

OR

b)  field length

Read two numbers in the range **01** to **99** to define the field length.

OR

c)  this is the last field (variable length)

AND

Field 1 Terminators

no field terminators



1 field terminator



2 field terminators



Read the field terminator character(s) from the HEX table.

Valid range of characters for all readers = **01-FE**.



ADVANCED FORMATTING

DEFINE FIELD 2 BY: EITHER

a)  field separator



Read the field separator character from the HEX table. Range of characters = **01-FE**.

discard separator



include separator



OR

b)  field length



Read two numbers in the range **01** to **99** to define the field length.

OR

c)  this is the last field (variable length)



AND

Field 2 Terminators

no field terminators



1 field terminator



2 field terminators



Read the field terminator character(s) from the HEX table.

Valid range of characters for all readers = **01-FE**.



ADVANCED FORMATTING

DEFINE FIELD 3 BY: EITHER

a)  field separator



Read the field separator character from the HEX table. Range of characters = **01-FE**.

discard separator



include separator



OR

b)  field length



Read two numbers in the range **01** to **99** to define the field length.

OR

c)  this is the last field (variable length)



AND

Field 3 Terminators

no field terminators



1 field terminator



2 field terminators



Read the field terminator character(s) from the HEX table.

Valid range of characters for all readers = **01-FE**.



ADVANCED FORMATTING

DEFINE FIELD 4 BY: EITHER

a) 

field separator



Read the field separator character from the HEX table. Range of characters = **01-FE**.

discard separator



include separator



OR

b) 

field length



Read two numbers in the range **01** to **99** to define the field length.

OR

c)

this is the last field (variable length)



AND

Field 4 Terminators

no field terminators



1 field terminator



2 field terminators



Read the field terminator character(s) from the HEX table.

Valid range of characters for all readers = **01-FE**.



ADVANCED FORMATTING

DEFINE FIELD 5 BY: EITHER

a)  field separator



Read the field separator character from the HEX table. Range of characters = **01-FE**.

discard separator



include separator



OR

b)  field length



Read two numbers in the range **01** to **99** to define the field length.

OR

c)  this is the last field (variable length)



AND

Field 5 Terminators

no field terminators



1 field terminator



2 field terminators



Read the field terminator character(s) from the HEX table.

Valid range of characters for all readers = **01-FE**.



ADVANCED FORMATTING

7

First Additional Fixed Field

no fixed field



1 character fixed field



2 character fixed field



3 character fixed field



4 character fixed field



5 character fixed field



6 character fixed field



After selecting **one** of the Additional Fixed Field codes, read the corresponding character(s) from the HEX table. Range of characters = **01-FE**.

Example:

4 Character Fixed Field

 $+ 4D + 41 + 49 + 4E = \text{MAIN}$



ADVANCED FORMATTING

8

Second Additional Fixed Field

no fixed field



1 character fixed field



2 character fixed field



3 character fixed field



4 character fixed field



5 character fixed field



6 character fixed field



After selecting **one** of the Additional Fixed Field codes, read the corresponding character(s) from the HEX table. Range of characters = **01-FE**.

Example:

3 Character Fixed Field

 $+ 53 + 45 + 54 = \text{SET}$



ADVANCED FORMATTING

9

Field Transmission

number of fields to transmit



Read one number in the range 1 to 7 for the number of fields to transmit. **Include only fields to be transmitted.**

Field Order Transmission

Read the codes corresponding to the fields to transmit in the order in which they are to be transmitted, see example.

field 1



field 3



field 5



additional field 2



field 2



field 4



additional field 1



Example:

The barcode is divided into 2 defined fields plus 1 additional fixed field.

Transmit in the order: Field 2, Additional Field 1, Field 1.

Number of Fields
to Transmit



+ 3 +

Field 2



+

Additional Field 1



+

Field 1





ADVANCED FORMATTING

10**Standard Formatting**

do not apply standard formatting



apply standard formatting



DRAGON™ D: After performing Advanced Formatting on the barcode read, Standard Formatting (Headers, Code Length, Code ID, Terminators) can be applied to the message to be transmitted.

DRAGON™ M: After performing Advanced Formatting on the barcode read, Standard Formatting (Code Length, Code ID) can be applied to the message to be transmitted.

11**End Format Definition**

end Format 1 definition



end Format 2 definition



end Format 3 definition



end Format 4 definition





ADVANCED FORMATTING

Enable Advanced Format

◆ no Advanced Formats enabled



Advanced Format 1

Enable



disable



Advanced Format 2

Enable



disable



Advanced Format 3

Enable



disable



Advanced Format 4

Enable



disable





ADVANCED FORMATTING

No Match Result

clear data - no transmission



transmit data using standard format



This selection determines the action to be taken when codes read do not conform to the advanced format requisites (no match).

- Codes not matching can be ignored, cleared from memory and not transmitted.
- Codes not matching can be transmitted using the Standard formatting (Headers, Code Length, Code ID, Terminators).

RADIO PARAMETERS

DRAGON™ M Series readers only

⊙	RADIO PROTOCOL TIMEOUT	⊙
⊙	POWER-OFF TIMEOUT	⊙
⊙	TRANSMISSION MODE	⊙
⊙	BEEPER CONTROL FOR RADIO RESPONSE	⊙
⊙	BATTERY TYPE	⊙
⊙	SINGLE STORE	⊙
⊙	BATCH MODE	⊙

1. Read the **Enter Configuration** code ONCE, available at the top of each page.
2. Read configuration codes from the desired groups.
 = Read the code and follow the procedure given
3. Read the **Exit and Save Configuration** code ONCE, available at the top of each page.



RADIO PARAMETERS

RADIO PROTOCOL TIMEOUT



radio protocol timeout



Read a number from the table where:

02-19 = timeout from **2** to **19** seconds

◆ 2 seconds

See par. 5.8.1 for details.

POWER-OFF TIMEOUT



power-off timeout



Read 2 numbers in the range 00-99:

00 = Power-off disabled; reader always ready

01-99 = corresponds to a max. 99 hour delay before power-off.

◆ power-off after 4 hours.

See par. 5.8.2 for details.

Enter configuration



RADIO PARAMETERS

Exit & Save configuration



TRANSMISSION MODE

◆ One-Way



Two-Ways



See par. 5.8.3 for details.

Enter configuration



Exit & Save configuration



RADIO PARAMETERS

BEEPER CONTROL FOR RADIO RESPONSE

◆ normal



only good decode



only good reception

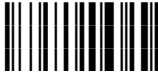

off



See par. 5.8.4 for details.

BATTERY TYPE

OM-DRAGON CRADLE ONLY

alkaline



NiMh



◆ auto-detect



Enter configuration



Exit & Save configuration



RADIO PARAMETERS

SINGLE STORE

◆ disable



two attempts



four attempts



six attempts



eight attempts



one attempt



three attempts



five attempts



seven attempts



nine attempts



See par. 5.8.5 for details

Enter configuration



Exit & Save configuration



RADIO PARAMETERS

BATCH MODE

◆ disable batch

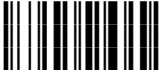

enable normal batch in
RAM



enable automatic batch
in RAM



enable normal batch in
EEPROM



enable automatic batch
in EEPROM



See par. 5.8.6 for details

The following batch management parameters are complete commands and do not require reading the Enter and Exit configuration codes.

start normal batch
transmission



#+BFlush

delete batch data



#+BReset

DISPLAY PARAMETERS

DRAGON™ M Series readers only

⊙	<i>DATE AND TIME</i>	⊙
⊙	<i>CONTRAST</i>	⊙
⊙	<i>FONT SIZE</i>	⊙
⊙	<i>BACKLIGHT</i>	⊙
⊙	<i>DISPLAY OFF TIMEOUT</i>	⊙
⊙	<i>DISPLAY MODE</i>	⊙
⊙	<i>KEYPAD</i>	⊙

1. Read the **Enter Configuration** code ONCE, available at the top of each page.
2. Read configuration codes from the desired groups.
 = Read the code and follow the procedure given
3. Read the **Exit and Save Configuration** code ONCE, available at the top of each page.

Enter configuration



Exit & Save configuration



DISPLAY PARAMETERS

DATE AND TIME



set date



Read 6 numbers for DDMMYY



set time



Read 4 numbers for HHMM

CONTRAST

lighter



darker



Read the code until the desired contrast is reached.

Enter configuration



Exit & Save configuration



DISPLAY PARAMETERS

FONT SIZE

◆ small



medium



large



BACKLIGHT

◆ backlight off



backlight on



DISPLAY-OFF TIMEOUT



timeout



Read 2 numbers in the range 00-99:

00 = disables display timeout (always on)

01 to 99 = timeout from 1 to 99 seconds.

◆ display-off after 8 seconds.



DISPLAY PARAMETERS

DISPLAY MODE

Normal



◆ local echo



clear display after decode



See par. 5.9.1 for details.

KEYPAD

disable reader keypad



◆ enable reader keypad and select characters



Read 3 HEX characters in the range **00-FE**, corresponding to the left, center and right keys respectively.

FF = KeyID disabled

◆ left = '<'
center = '='
right = '>'

See par. 6.2 for details.

5 REFERENCES

5.1 RS232 PARAMETERS

5.1.1 Handshaking

Hardware handshaking: (RTS/CTS)

The RTS line is activated by the decoder before transmitting a character. Transmission is possible only if the CTS line (controlled by the Host) is active.

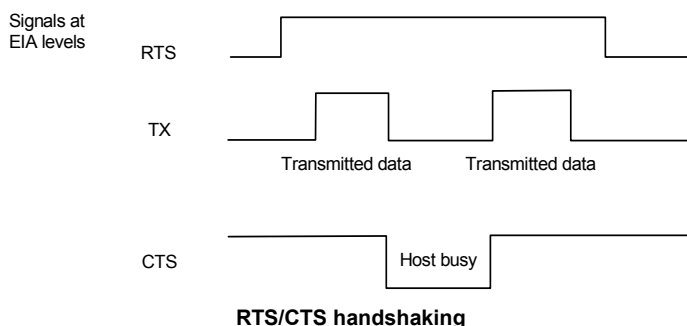

Software handshaking: (XON/XOFF)

During transmission, if the Host sends the XOFF character (13 Hex), the decoder interrupts the transmission with a maximum delay of one character and only resumes when the XON character (11 Hex) is received.

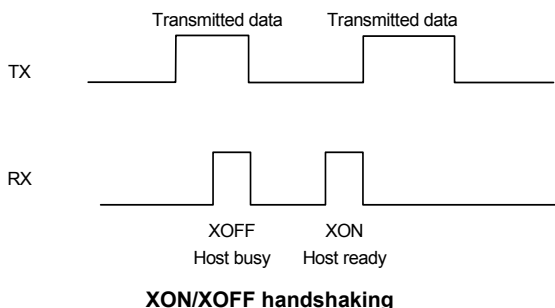

5.1.2 ACK/NACK Protocol

DRAGON™ D Readers

This parameter sets a transmission protocol in which the Host responds to the reader after every code transmitted. The Host sends an ACK character (06 HEX) in the case of good reception or the NACK character (15 HEX) requesting re-transmission, in the case of bad reception.

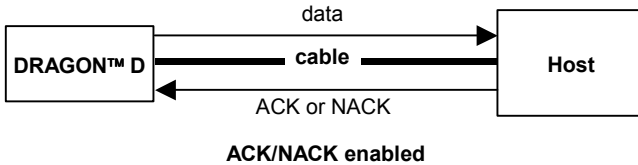

If the reader does not receive an ACK or NACK, transmission is ended after the RX Timeout, see par. 5.1.4.

Selection of the ACK/NACK protocol temporarily disables FIFO buffering, see par. 5.1.3.

DRAGON™ M Readers

The transmission protocol takes place between reader, cradle and Host. The reader passes its data (code read) to the cradle which sends it to the Host. The management of responses (from Host or cradle) depends on the Transmission Mode parameter, see par. 5.8.3.

In the following descriptions the completed transmission is indicated by the Beeper Control for Radio Response parameter with its default setting to Normal, see par. 5.8.4.

When ACK/NACK is disabled (in One-Way tx mode), there is no control from cradle to Host transmission, the reader responds with the good reception tone.

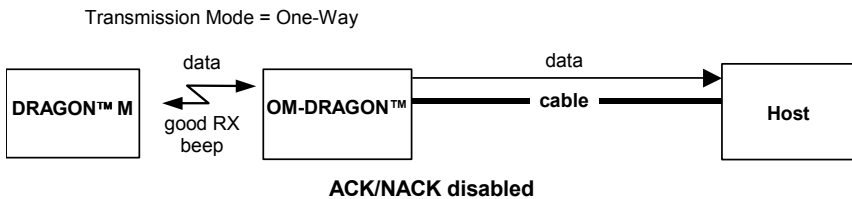

Transmission Mode = Two-Ways

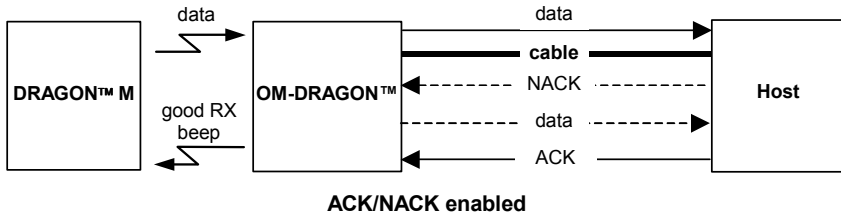

When ACK/NACK is enabled (in Two-Way tx mode), the Host sends an ACK character (06 HEX) in the case of good reception or the NACK character (15 HEX) requesting re-transmission, in the case of bad reception. Only after the ACK character is received by the OM-DRAGON™ does the reader respond with the good reception tone.

If the OM-DRAGON™ does not receive an ACK or NACK, transmission is ended after the RX Timeout, see par. 5.1.4. See also Radio Protocol Timeout, par. 5.8.1.

Selection of the ACK/NACK protocol temporarily disables FIFO buffering see par. 5.1.3.

5.1.3 FIFO

DRAGON™ D Readers

This parameter determines whether data (barcodes) are buffered on a First In First Out basis allowing faster data collection in certain cases for example when using slow baud rates and/or hardware handshaking.

If the FIFO buffering is enabled, codes are collected and sent out on the serial line in the order of acquisition. About 800 characters can be collected (buffer full), after which the reader signals an error and discards any further codes until the transmission is restored.

If the FIFO buffering is disabled, each code must be transmitted before another one can be read.

DRAGON™ M Readers

If enabled, the OM-DRAGON™ collects all messages sent by DRAGON™ M and sends them in order of acquisition to the connected Host.

If disabled, DRAGON™ M blocks message transmission until the OM-DRAGON™ has completed transmission towards the Host.

5.1.4 RX Timeout

When the RS232 interface is selected, the Host can be used to configure the device by sending it command strings (see appendix A).

This parameter can be used to automatically end data reception from the Host after the specified period of time.

If no character is received from the Host, after the timeout expires, any incomplete string (any string not terminated by <CR>) is flushed from the device buffer.

5.2 PEN PARAMETERS

5.2.1 Minimum Output Pulse

This parameter sets the duration of the output pulse corresponding to the narrowest element in the barcode. In this way the code resolution is controlled by the signal sent to the decoder, independently of the physical resolution of the code read.

The shortest pulse (200 μ s) corresponds to a high resolution code emulation and therefore a shorter transfer speed to the decoder (for decoders able to work on high resolution codes). Likewise, longer pulses correspond to low resolution code emulation and therefore a longer transfer time to the decoder.

5.2.2 Conversion to Code 39 and Code 128

DRAGON™ D Series Readers

When using these readers it is possible to convert all codes to Code 39. By disabling this option the decoded codes will be transmitted in their original format; except for the following codes which are ALWAYS converted into Code 39 format:

Codablock-A, Codablock-F Standard and EAN, MSI, Plessey, Telepen, Delta IBM, Code 11, Code 16K, Code 49, PDF417.

DRAGON™ M Series Readers

When using these readers it is possible to choose between converting the decoded codes into either Code 39 format or Code 128 format. It is not possible to disable conversion.

5.2.3 Overflow

This parameter generates a white space before the first bar and after the last bar of the code. The selections are as follows:

- narrow = space 10 times the minimum output pulse.
- medium = space 20 times the minimum output pulse.
- wide = space 30 times the minimum output pulse.

5.2.4 Output and Idle Levels

The following state diagrams describe the different output and idle level combinations for Pen emulation:

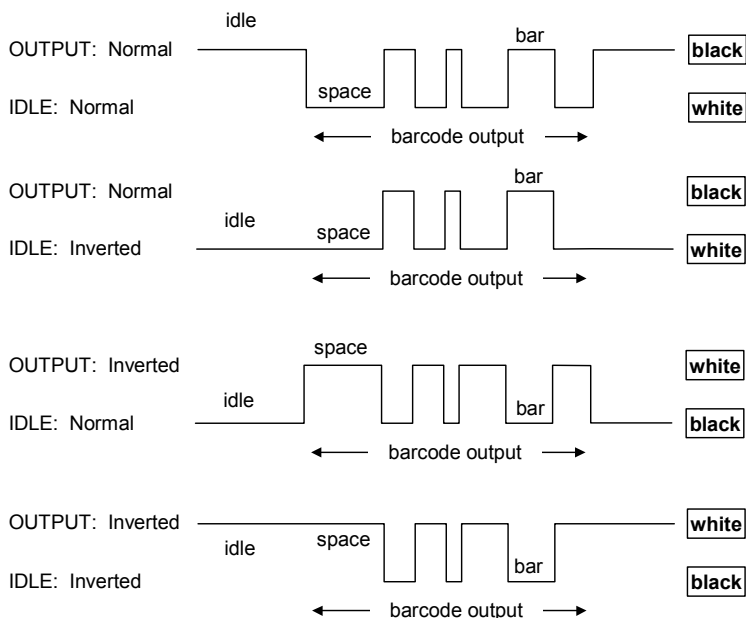

Output and Idle Levels

5.2.5 Inter-Block Delay

For the PEN Emulation interface, data are sent to the Host in fixed size blocks of 20 characters each. The inter-block delay parameter allows setting a delay between each block sent to the Host.

5.3 NETWORK PARAMETERS

5.3.1 Slave Address Range First/Last

These parameters define the valid addresses for the Slave cradles on the network. Valid values are in the range 0 to 1999. However, the maximum number of cradles in a single network is 16, (including the Master if present). All cradles in the system must have different addresses.

To reduce system boot time, it is recommended to number the Slaves consecutively, while it is not necessary that the Master cradle address is contained in the range. The network addresses correspond to the radio addresses, see par. 4.6.

At system power-up, the Master searches for and initializes all the Slaves found in the valid address range. During this phase the yellow LED on the Master cradle blinks. The time to complete the start up procedure varies depending on the complexity of the network but is typically between a few seconds to a few minutes. Start up cannot be interrupted. At the end of this procedure the system will be operative and can collect data from all devices.



CAUTION

All Slaves must be powered up either before or together with the Master. Slaves successively powered will not be recognized by the system even if their address is in the specified range.

5.3.2 Warning Message

The Master cradle can transmit warning messages to the Host regarding some network errors.

/*Slave xxxx not responding*/: when the Master can no longer communicate with the specified Slave previously identified at start up.

/*Frame out of sequence for terminal xxxx*/: if a gun is sending data packets out of sequence. This can happen if there are transmission problems on the network (either connection or communication), or if the gun has correctly transmitted data to a device not on the network (gun configuration error).

The message is sent in the following format:

"Message" CR LF

5.3.3 Master Header/Terminator Selection

In addition to the standard header/terminator selection, the Master cradle can add its own header/terminator to the entire message sent to the Host.

In the STAR-System™ network headers and terminators for all RF Devices are disabled by default.

The Master header and terminator default values are as follows depending on the interface selection towards the Host:

RS232:	no header, terminator CR-LF
WEDGE:	no header, terminator ENTER

See par. 5.4.1 and 5.4.2.

5.4 DATA FORMAT

For an overview of Message Formatting see Chapter 6.

5.4.1 Header/Terminator Selection

The header/terminator selection is not effected by the reading of the restore default code. In fact, header and terminator default values depend on the interface selection:

RS232:	no header, terminator CR-LF
WEDGE:	no header, terminator ENTER

These default values are always restored through the reading of RS232 or WEDGE interface selection code, see par. 4.7.

For the WEDGE interface, the following extended keyboard values can also be configured:

EXTENDED KEYBOARD TO HEX CONVERSION TABLE				
	IBM AT IBM 3153 APPLE ADB	IBM XT	IBM 31xx, 32xx, 34xx, 37xx	Wyse Digital
HEX	KEY	KEY	KEY	KEY
83	ENTER	ENTER	FIELD EXIT	RETURN
84	TAB	TAB	TAB	TAB
85	F1	F1	F1	F1
86	F2	F2	F2	F2
87	F3	F3	F3	F3
88	F4	F4	F4	F4
89	F5	F5	F5	F5
8A	F6	F6	F6	F6
8B	F7	F7	F7	F7
8C	F8	F8	F8	F8
8D	F9	F9	F9	F9
8E	F10	F10	F10	F10
8F	F11	ESC	F11	F11
90	F12	BACKSPACE	F12	F12
91	HOME	HOME	ENTER	F13
92	END	END	RESET	F14
93	PG UP	PG UP	INSERT	F15
94	PG DOWN	PG DOWN	DELETE	F16
95	↑	↑	FIELD -	UP
96	↓	↓	FIELD +	DOWN
97	←	←	ENTER (Paddle)	LEFT
98	→	→	PRINT	RIGHT
99	ESC	ESC		ESC
9A	CTRL (Right)	CTRL (Right)		CTRL (Right)
9B	Euro	Space	Space	Space

For all readers using Wedge interface, all values from **9C** to **FE** send the Space character.



5.4.2 Set Custom Extended Header/Terminator Keys

The extended Header/Terminator keys for **Wedge Interface users** can be customized by defining them through a simple keyboard setting procedure.

For example, the Numeric Keypad keys can be set for use as Headers or Terminators by substituting the default extended keys using this procedure.

The type of computer or terminal must be selected before activating the keyboard setting command.

Press and release a key to set it.

Some characters may require more than one key pressed simultaneously during normal use (refer to the manual of your PC or terminal for keyboard use). The exact sequence must be indicated to the reader in this case pressing and releasing the different keys.

Example:

If one has to press the "Shift" and "4" keys simultaneously on the keyboard to transmit the character "\$" to the video, to set the "\$", press and release "Shift" then press and release "4".

Each pressed and released key must generate an acoustic signal on the reader, otherwise repress the key. Never press more than one key at the same time, even if this corresponds to the normal use of your keyboard.

Press "Back space" to correct a wrong key entry. In this case the reader emits 2 beeps.

Note: "CAPS LOCK" and "NUM LOCK" must be off before starting the keyboard setting procedure. "SHIFT" must be repressed for each character and cannot be substituted by "CAPS LOCK".

set custom extended header/terminator keys



Read the code above.

- **If the first 4 KEYS (Shift, Alt, Ctrl, and Backspace) are not available on your keyboard, you can only substitute them with keys not used, or substitute them with each other.**
- Keys 5 to 28 must be defined

Press the desired keys in the following order:

The reader signals the end of the procedure with 2 beeps indicating the keys have been registered.

CUSTOM EXTENDED KEYBOARD SETTING TABLE		
		Custom
Order	HEX	KEY
01	-	Shift
02	-	Alt
03	-	Ctrl
04	-	Backspace
05	83	
06	84	
07	85	
08	86	
09	87	
10	88	
11	89	
12	8A	
13	8B	
14	8C	
15	8D	
16	8E	
17	8F	
18	90	
19	91	
20	92	
21	93	
22	94	
23	95	
24	96	
25	97	
26	98	
27	99	
28	9A	

DRAGON™ M Series Only

When working with DRAGON™ M series readers, the keyboard setup functioning is signaled by the LEDs on the OM-DRAGON cradle. Each key stroke corresponds to a double blinking of the green LED.

By pressing the Backspace key the red LED on the OM-DRAGON cradle blinks, while the green LED stays on.



CAUTION

Do not place the reader into the OM-DRAGON cradle during this procedure. Otherwise, the battery charging will occur modifying the LEDs functioning.

Once the procedure has been completed, the green LED turns off.

5.4.3 Address Stamping

It is possible to include the reader and cradle addresses in the message sent to the host. The Reader Address Stamping and the Cradle Address Stamping parameters consist of a 4-digit number in the range 0000 to 1999.

For message output format, refer to chapter 6.

5.4.4 Address Delimiter

The Address Delimiters allow a character to be included to separate the Reader and Cradle Address stamping fields from the next fields in the message. Any character can be included in the hexadecimal range from 00 to FE.

For message output format, refer to chapter 6.

5.4.5 Time Stamping Format

The Time Stamping parameter sets the format for hour and date information. It consists of 1 or 2 groups of numbers, each one made up of 6 decimal digits.

For example, setting the Hour/Minutes/Seconds/Month/Day/Year format, the information *17:03:16 on June 12, 2002* will be formatted as 170316061202.

5.4.6 Time Stamping Delimiter

The Time Stamping Delimiter allows a character to be included to separate the Time Stamping field from the next field in the message. Any character can be included in the hexadecimal range from 00 to FE.

5.5 POWER SAVE

5.5.1 Sleep State

This mode allows the μ P in the reader to enter a “Sleep” state for minimum power consumption. For D-series readers, this command is only valid when hardware trigger type is selected.

Before entering Sleep mode, the following are verified:

- no commands coming from Host
- no data being transmitted to Host
- Enter Sleep Timeout ended (see par.5.5.2)

To exit Sleep mode press the trigger.

For M-series readers, sleep state is entered immediately after reading a code and is not configurable. To exit Sleep mode press the trigger.

5.5.2 Enter Sleep Timeout

For readers that have the Sleep state enabled, this timeout determines when the reader will enter this state.

5.6 READING PARAMETERS

5.6.1 Trigger Signal

This mode determines how the reading phase is controlled when the hardware trigger type is selected:

- trigger active level: the reader goes ON when the trigger is pressed and goes OFF when it is released
- trigger active pulse: the reader goes ON at the first trigger press and goes OFF only at a second press

5.6.2 Trigger-Off Timeout

When this timeout is selected, the reader turns OFF automatically after the desired period of time.

5.6.3 Reads per Cycle

In general, a **reading cycle** corresponds to the ON + OFF times of a device. The resulting effects of this parameter on code reading depend on other related configuration conditions. Here are the definitions of ON and OFF times.

- For readers using the software trigger parameter (FLASH MODE), a reading cycle corresponds to the *flash on* + *flash off* times. Code reading takes place during the *flash on* time.
- For readers using the *hardware trigger* parameter, a reading cycle corresponds to a trigger press (ON) + one of the following OFF events:
 - trigger release (for *trigger active level*)
 - a second trigger press (for *trigger active pulse*)
 - trigger-off timeout* (see par. 5.6.2).

When **one read per cycle** is selected, the device decodes only one code during the ON period and immediately turns the reader OFF. It is only possible to read another code when the next ON time occurs.

In **multiple reads per cycle**, the ON period is extended so that the device can continue decoding codes until an OFF event occurs. For software trigger mode, the *flash on* period is immediately reset after each read and therefore extended. If another code is decoded before the reset *flash on* period expires, it is again reset and the effect is that the device remains ON, decoding codes until the *flash on* or *timeout* period expires.

The Safety Time parameter should be used in this case to avoid unwanted multiple reading of the same code, see par. 5.6.4.

5.6.4 Safety Time

Safety time prevents the device from immediately decoding the same code more than once. Same code consecutive reading can be disabled requiring the reader to be removed from the code (no decoding) for at least 400 ms, or a timeout can be set up to 9.9 seconds before the decoder will accept the same code. Reading is immediate if the code changes.

5.7 DECODING PARAMETERS



CAUTION

These parameters are intended to enhance the decoding capability of the reader for particular applications. Used incorrectly, they can degrade the reading performance or increase the possibility of a decoding error.

5.7.1 Ink-Spread

The ink-spread parameter allows the decoding of codes which are not perfectly printed because the page texture tends to absorb the ink.

5.7.2 Overflow Control

The overflow control parameter can be disabled when decoding codes printed on small surfaces, which don't allow the use of an overflow space.

This command does not effect code families 2/5, Code 128 and Code 93.

This command is forced (enabled) when PDF417 codes are enabled.

5.7.3 Interdigit Control

The interdigit control parameter verifies the interdigit spacing for code families Code 39 and Codabar.

5.8 RADIO PARAMETERS (M SERIES ONLY)

5.8.1 Radio Protocol Timeout

This parameter sets the valid time to wait before transmission between the M series reader and OM-DRAGON cradle is considered failed.

This parameter should be set taking into consideration the radio traffic (number of readers in the same area).

If the RS232 interface is used with ACK/NACK enabled, this parameter should be at least equal to the Rx Timeout parameter for low traffic environments. It should be increased if there are many readers in the same area.

It can be set between 2 and 19 seconds.

5.8.2 Power-Off Timeout

If this command is enabled, after the desired timeout in hours, the DRAGON™ batteries are disconnected and all power consumption ceases. To restore power, press the trigger once. The reader will now be ready to read codes.

Power-off does not effect configuration parameters.

5.8.3 Transmission Mode

This parameter determines whether the reader receives responses or messages from the Host or not. In One-Way tx mode, neither Host nor cradle responds to the reader.

In Two-Way tx mode, the reader must receive a response from either the cradle or the Host.

The cradle responds (empty message) to the reader, only after good transmission to the Host, for the following conditions: ACK/NACK enabled, see par. 5.1.2; WEDGE or PEN interface. For these conditions, it is suggested to prolong the Radio Protocol Timeout, see par. 5.8.1.

Enabling Two-Way tx mode temporarily disables FIFO buffering see par. 5.1.3.

With ACK/NACK disabled, the Host responds to the reader (through the cradle) with an answer message (message to reader display or command to reader), see par. 6.1 and the following figure.

Transmission Mode = Two-Ways

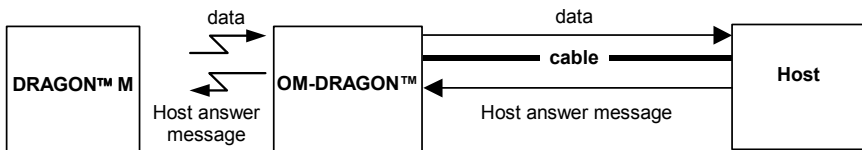

5.8.4 Beeper Control for Radio Response

For M-Series readers, the data entry good read tone normally results in two beeps; the first indicates that the reader has decoded the code, the second indicates whether OM-DRAGON has received the data.

This can be changed according to the following selections:

- ◆ Normal: both good decode and good reception are signaled (two beeps).
- ◆ Only Good Decode: only the first beep indicating a good read is signaled.
- ◆ Only Good Reception: only the second beep indicating a good reception is signaled.
- ◆ Off: Neither good read nor good reception beeps are signaled.

For all configurations, any transmission errors will always be signaled.

5.8.5 Single Store

When single store mode is enabled, if the DRAGON™ M fails to transmit a code to the cradle, it enters a special operating mode that prevents the user from reading barcodes. When such operating mode is entered, the trigger no longer enables barcode reading but is used to retry transmission itself for the number of attempts selected in configuration. Once the transmission is successful the reader returns to the standard mode. If transmission is not successful after the number of configured attempts, the code is discarded.

Single store may be useful if you often read codes at the limit of the coverage area and there is a chance that code transmission can fail. In such case single store allows you to move to a more favorable position or location (i.e. closer to the cradle) and retry transmission without the necessity of re-reading the code since it is already stored in the reader.

Conversely, if single store is disabled, and the user wants to retry transmission, the code must be read again, and therefore the attempt must be made from basically the same location. If the user gives up, he does not know if the transaction was successful. (Actually the transmission could have been successful but the cradle may have been unable to acknowledge the message). There are applications in which there is no risk of transmission failure. In such cases it may be better to disable single store so that the user perceives a more consistent behavior of the trigger in that it always corresponds to code reading.

5.8.6 Batch Mode

This Operating Mode allows storing read codes in the internal gun memory. The stored codes are transmitted to the base station at a later time according to the type of batch mode selected.

Batch mode can be enabled either manually (normal batch mode) or automatically.

Normal batch mode temporarily suspends radio communication between gun and base station allowing codes to be stored in the gun on a FIFO basis. This can be useful for example, if codes must be read from a location where there is no radio network. Upon returning to the system working area, this mode requires reading the **Start Normal Batch Transmission** barcode to successively transmit the list of stored codes to the base station. The FIFO management assures that the first code read will be the first code to be transmitted to the base station.

The **Delete Batch Data** barcode allows canceling all barcode data stored in the gun.

Automatic batch mode allows codes to be stored in the gun on a FIFO basis whenever the gun is out of radio range. In this case radio communication is not suspended and transmission is attempted after each code read. If transmission cannot be successfully completed, then the code is added to the list. When the gun returns in range, transmission of the codes to the base station resumes automatically, according to the selected communication protocol, upon simply pressing and releasing the trigger or by successfully reading a new code.

Each code is listed on the gun display together with its identifying position number and its total number of characters. The three keys under the display have the following function in batch mode:

	Key	Function
▲	(left) Key	Scroll up in list
ENTER	(center) Key	Delete highlighted code
▼	(right) Key	Scroll down in list

In batch mode, the selected Transmission Mode determines the behavior of the gun at the time the list of codes is transmitted. If One-way mode is enabled, the codes are transmitted one after the other without interruption. In Two-way mode, after transmitting each code, the gun waits for the Host answer message to be shown on the display. Therefore, in Two-way transmission mode and normal batch mode, the **Start Normal Batch Transmission** barcode must be read after each code to continue, whereas with automatic batch mode just pull and release the trigger after each code.

The code which has a transmission pending is shown on the display in reverse video indicating that it cannot be deleted.

The selection of batch mode in EEPROM provides the advantage of permanently saving data in the EEPROM to avoid losing them if for example the batteries run down.

The RAM selection allows more data to be saved and is transmitted more quickly to the base station. For example, for a list of codes having an average of 20 characters each, the EEPROM can store about 60 codes while the RAM can store almost 100.

5.9 DISPLAY PARAMETERS (SOME M SERIES MODELS ONLY)

5.9.1 Display Mode

The user can control the gun display behavior according to the following selections:

Normal mode: When a barcode is read with the gun:

- The code is sent to the Host.
- The gun display is not cleared. Therefore if any previous data was displayed on the gun screen it remains.
- There is no Local Echo to the gun display.

Clear Display After Decode mode: When a barcode is read with the gun:

- The code is sent to the Host.
- The gun display is cleared. Therefore if any previous data was displayed on the gun screen it is cancelled and the screen remains blank.
- There is no Local Echo of the code to the gun display.





Local Echo mode: When a barcode is read with the gun:

- The code is sent to the Host.
- The gun display is cleared.
- The code is also sent to the gun display (Local Echo).
- The cursor is positioned after the last printed character on the gun display.

Host messages sent to the gun are always written to the gun display.

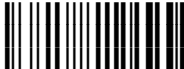
5.10 CONFIGURATION EDITING COMMANDS

The following commands carry out their specific function and then exit the configuration environment.

Command	Description
	Restore DRAGON™ reader default configuration (see the relative Quick Reference Manual for default settings)
	Transmit the DRAGON™ D or DRAGON™ M Software release
	Transmit DRAGON™ reader configuration in ASCII format. This command is not effective with Pen emulation interface.
	Restore OM-DRAGON™ default configuration (see the Quick Reference Manual for default settings)
	Transmit the OM-DRAGON™ Software release
	Transmit OM-DRAGON™ configuration in ASCII format. This command is not effective with Pen emulation interface.

5.11 CONFIGURATION COPYING COMMANDS

5.11.1 Copy DRAGON™ D-Series

Procedure:

- ① Connect the **master** (correctly configured reader) and the **slave** (reader to be configured) together through two RS232 serial interface cables and external power supply. Accessory cables and power supply are available from your Datalogic distributor to provide this connection.

RS232 Cables: CAB363 & CAB364 or CAB320 & CAB328

Power Supply: PG5

- ② Using the **slave** reader, read the Restore Default barcode and then the RS232 interface barcode from chapter 4 of this manual or from the Quick Reference Manual.
- ③ With the **master** reader, read the Configuration Copy barcode below.

Copy Configuration



The configuration will be copied from the master to the slave reader. The slave reader signals the end of the procedure with a series of beeps.

Note: The master reader can be configured for any interface.

5.11.2 Copy DRAGON™ M-Series

Procedure:

- ① Using the **slave** reader and its OM-DRAGON™ cradle, follow the initialization procedure in chapter 4 of this manual or from the Quick Reference Manual.
- ② With the **master** DRAGON™ M (correctly configured reader), read the Copy Configuration barcode below. Then place it onto an OM-DRAGON™ cradle within 10 seconds. The reader will beep indicating the configuration has been copied.

The configuration will be simultaneously sent over the RS232 interface of the OM-DRAGON™. If this causes undesired effects disconnect the RS232 cable between the PC and OM-DRAGON™ during this process.

Copy Configuration



\$+ZZ0\$-

- ③ With the **slave** DRAGON™ M, read the Get Configuration barcode below. Then place it onto the **same** OM-DRAGON™ cradle used in the step above. The slave reader's address will not be changed.

Get Configuration



\$+ZZ2\$-

The configuration will be copied from the master to the slave DRAGON™ M. The slave DRAGON™ M signals the end of the procedure with a series of beeps. It is now ready to be used with its own OM-DRAGON™ cradle.

- ④ Repeat the procedure above to configure other slave readers. The OM-DRAGON™ can continue to configure slave readers until it receives another command or data.

5.11.3 Copy OM-DRAGON™

Procedure:

- ① Using the **slave** reader and its OM-DRAGON™ cradle, read the Restore Default barcode, set the radio address, and then read the RS232 interface barcode from chapter 4 of this manual or from the Quick Reference Manual.

- ② Connect the **master** OM-DRAGON™ and the **slave** OM-DRAGON™ (cradle to be configured) together through two RS232 serial interface cables and external power supply. Accessory cables and power supply are available from your Datalogic distributor to provide this connection.

RS232 Cables: CAB363 & CAB364 or CAB320 & CAB328

Power Supply: PG12

- ③ Read the Configuration Copy barcode below with a reader. Then place it onto the **master** OM-DRAGON™ cradle.

Copy Configuration



\$+ZZ3\$-

The configuration will be copied from the master OM-DRAGON™ to the slave OM-DRAGON™. The reader signals the end of the procedure with a series of beeps.

- ④ Repeat the procedure above to configure other slave cradles.

Note: The master OM-DRAGON™ can be configured for any interface.

5.12 C-DRAGON™ CONFIGURATION

It is possible to configure the C-DRAGON™ battery charger for the particular battery installed in the DRAGON™ M reader. Selecting the proper battery type increases battery charging efficiency and decreases the time necessary for complete charging.

1. With the DRAGON™ M read one of the following codes:

◆ **Auto-Detect**



Alkaline



NiMh/NiCd



The green LED on the DRAGON™ M will blink, signaling the reader has accepted the command.

2. Insert the reader into the charger within 10 seconds. The green LED turns off and a short beep is emitted

6 MESSAGE FORMATTING

The system always provides gun to host data communication using the following message formatting:

Output Message from DRAGON™ D or DRAGON™ M Stand Alone Towards Host
**[Header] [Gun_Addr] [Gun_Addr_delimiter] [Cradle_Addr] [Cradle_Addr_delimiter]
 [Time stamp] [Ts_delimiter] [Code ID] [Code Length] CODE [Terminator]**

[Items in square brackets are optional.]

Output Message from DRAGON™ M STAR-System™ Towards Host
[Header] [Time stamp] [Ts_delimiter] [Code ID] [Code Length] CODE [Terminator]

[Items in square brackets are optional.]

For DRAGON™ M models with display, if the RS232 interface is selected for communication between the Host and the OM-DRAGON™ cradle, then the following additional communications between Host and Gun can occur:

- The Host can send messages to any gun associated with that cradle to control the Gun's display, LEDs and beeper.
- The Gun can send up to 3 user-defined characters to the Host using the 3 command keys on the gun.

These communications and their relative message formatting are detailed in the following paragraphs.

6.1 MESSAGES FROM HOST TO GUN

The general format is:

[Gun_Addr] [Gun_Addr_delimiter] MESSAGE CR

NOTE:

- If you have enabled the Gun Address Stamping or the Gun Address Delimiter, you **must** specify them in every message.

- If you have **not** enabled the Gun Address Stamping or the Gun Address Delimiter, you **must not** specify them. In this case all messages will be implicitly addressed to the 'binded' gun of the cradle directly connected to the serial line.
- The gun can only receive messages only if two-way mode is enabled. (See par. 5.8.3, "Transmission Mode", command is on page 130).
- Messages cannot start with '\$+' because they would be interpreted as a configuration command.
- You can send a message to the gun only while it is on. This happens when it has sent a message to the host and the radio timeout has not yet expired. (See par. 5.8.1, "Radio Protocol Timeout"; command is on page 129).
- If you want to control the gun's beeper from the host, you will also probably want to disable the good transmission beep that is emitted when the code is received from the cradle. (See command on page 83).

The message field can store plain text and escape sequences.

- Escape sequences are interpreted as commands.
- Plain text is directly printed on the display. If writing beyond the end of line, the display does not wrap automatically. Extra characters are ignored. Control characters are not interpreted (i.e. LF, FF, etc.).

6.1.1 Cursor Control

ESC [nA	Up <i>n</i> rows, no scroll
ESC [nB	Down <i>n</i> rows, no scroll
ESC [nC	Right <i>n</i> columns
ESC [nD	Left <i>n</i> columns
ESC [G	CR
ESC [r; cH	Move to row <i>r</i> , column <i>c</i> (ESC[1;1H is the upper left character position of the display)
ESC D	Down 1 row, with scroll
ESC E	CR and cursor down 1 row with scroll
ESC M	Up 1 row and scroll

NOTES:

- Since CR is used as the message terminator, you must use ESC [G or ESC E to print a CR.
- The cursor row position **is not** affected by the currently selected font. The display always has 4 rows, so when writing with the large font, actually two rows

are written to: the current one and the one below it. You will need two ESC E commands to step from one row to the next when using the large font.

- The cursor column position **is** affected by the currently selected font. Therefore, column 6 is 36 pixels from the left border only if you last selected the 6x8 font; otherwise it could be 48 or 72 pixels from the left border.

6.1.2 Font Selection

ESC [0 m	Normal mode
ESC [7 m	Reverse mode
ESC # 4	Large font: subsequent characters are written on the current row and the row below it using the 12x16 font which allows for two rows of eight characters on the display.
ESC # 5	Normal font: subsequent characters are written using the 6x8 font which allows for four rows of sixteen characters on the display.
ESC # 7	Medium font: subsequent characters are written using the 8x8 font which allows for four rows of twelve characters on the display.

6.1.3 Clearing Display

ESC [0 K	From cursor position to end of line inclusive
ESC [1 K	From beginning of line to cursor position (not inclusive)
ESC [2 K	Entire line
ESC [0 J	From cursor position to end of display inclusive
ESC [1 J	From beginning of display to cursor position (not inclusive)
ESC [2 J	Entire display; moves cursor to upper left corner on display

6.1.4 LED and Beeper Control

ESC [0 q	Emit short High tone + short delay
ESC [1 q	Emit short Low tone + short delay
ESC [2 q	Emit long Low tone + short delay
ESC [3 q	Emit good read tone
ESC [4 q	Emit bad tx tone
ESC [5 q	Wait 100 ms
ESC [6 q	Turn on the green LED
ESC [7 q	Turn off the green LED
ESC [8 q	Turn on the red LED
ESC [9 q	Turn off the red LED

The LED control escape sequences are intended to activate the LEDs for short periods of time and can be used in combination with the Beeper. The LED and Beeper will be controlled by the system after the entire command sequence is interpreted.

Example:

ESC [6 q ESC [3 q ESC [7 q Turns on the green LED, emits a good read tone, and turns off the green LED.

ESC [6 q ESC [5 q ESC [7 q Turns on the green LED for 100 ms and then turns off the green LED.

6.1.5 Setting RTC

ESC [0 p d d m m y y	Set date to day, month, year
ESC [1 p h h m m	Set time to hours, minutes; seconds are automatically set to 00.

6.2 MESSAGES FROM GUN COMMAND KEYS

The DRAGON™ M series guns with display have 3 command keys that can each be associated with a character to send to the host.

By pressing the keys on the gun, the associated character with its relative message formatting is sent to the Host. For example, keys can be used to select items from a menu sent to the gun display by the application program.

The general format is:

**[Header] [Gun_Addr] [Gun_Addr_delimiter] [Cradle_Addr] [Cradle_Addr_delimiter]
[Time stamp] [Ts_delimiter] [Code ID] [Code Length] KeyID [Terminator]**

[Items in square brackets are optional.]

The messages are handled by the system as if they were barcodes, that's why **KeyID** can have so many fields appended to it. If in your application there is some chance of reading a 1-char barcode identical to **KeyID**, the way you can distinguish between the two is to enable the Code ID: The **KeyID** is the only 1-character long EAN 8 code.

Refer to par. 5.3 for a complete description of the optional message fields in square brackets.

The default characters associated with each key (**KeyID**) are shown in the following table:

Default Key Identifiers		
	Key	KeyID
▲	(left) Key	'<'
ENTER	(center) Key	' '
▼	(right) Key	'>'

7 TECHNICAL FEATURES

7.1 DRAGON™ D

	STD	HD	LR
Electrical Features			
Supply Voltage	4 to 20 Vdc		
Consumption			
@ 4V	250 mA		
@ 5V	170 mA		
@ 20 V	40 mA		
Sleep Mode	2 mA		
Laser Features			
Light Source	VLD between 630~680 nm		
Scan Rate	35 ± 5 scans/sec		
Power (max) in mW	0.9 mW	0.4 mW	1.4 mW
Scan Angle	42°	37°	23°
PCS minimum (Datalogic Test Chart)	15%	40%	40%
Resolution maximum			
mm	0.08	0.06	0.25
mils	3	2.5	10
Reading Field Width	see reading diagrams (par. 7.6)		
Laser Safety Class (EN 60825-1 / CDRH)	2		
Environmental Features			
Working Temperature (°C)	-10 to +50	0 to +40	-10 to +50
Storage Temperature (°C)	-20 to +50		
Humidity	90% non condensing		
Drop resistance (on concrete)	IEC 68-2-32 Test ED		
Protection	sealed against rain and dust		
Mechanical Features			
Weight (without cable)	about 270 g.		
Dimensions	203 x 117 x 69 mm		
Material	ABS and Polycarbonate molded with rubber		

7.2 DRAGON™ M

	STD	LR
Electrical and General Features		
Battery Type	2 AA NiMh* batteries	
Recharge Time	2 hours	
Operating autonomy (typ. continuous reading)	60,000 reads	
Display (Only available with some models)	LCD 4 lines x 16 chars Programmable font and backlight	
Indicators	Laser On / battery low LED (red) Good Read LED (green) Programmable Beeper	
Laser Features		
Light Source	VLD between 630~680 nm	
Scan Rate	35 ± 5 scans/sec	
Power (max) in mW	0.9 mW	1.4 mW
Scan Angle	42°	23°
PCS minimum (Datalogic Test Chart)	15%	40%
Resolution maximum mm mils	0.08 3	0.25 10
Reading Field Width	see reading diagrams (par. 7.6)	
Laser Safety Class (EN 60825-1 / CDRH)	2	
Environmental Features		
Working Temperature (°C)	-10 to +40	
Storage Temperature (°C)	-20 to +50	
Humidity	90% non condensing	
Drop resistance (on concrete) with display without display	1.5 m 1.8 m	
Protection	sealed against rain and dust	
Mechanical Features		
Weight (without cable)	about 340 g.	
Dimensions	203 x 117 x 69 mm	
Material	ABS and Polycarbonate molded with rubber	

* It is possible to employ also NiCd or non-chargeable Alkaline AA batteries.

7.3 OM-DRAGON™ / C-DRAGON™

	OM-DRAGON™	C-DRAGON™
Electrical and General Features		
Supply Voltage	9 to 28 Vdc	
Power Consumption max.	8 W (charging) *	
Indicators	Charger on LED (red) Charge completed LED (green) Power/Data LED (yellow)	
Recharge Time NiMh / NiCd batteries	2 hours	
Host Interfaces		
RS232	300 to 19200 baud	
WEDGE	IBM AT or PS/2, XT, PC Notebook, IBM SURE1, IBM 3153, 31xx, 32xx, 34xx, 37xx terminals, Wyse terminals, Digital VT terminals, Apple ADB Bus supported	
PEN Emulation	Selectable minimum pulse from 200 μ S to 1.2 mS	
Environmental Features		
Working Temperature (°C)	-10 to +40	
Storage Temperature (°C)	-20 to +60	
Humidity	90% non condensing	
Protection	IP40	
Mechanical Features		
Weight (without cable)	about 600 g.	
Dimensions	185 x 115 x 104 mm	
Material	ABS	

* Having a switching regulator inside, the OM-DRAGON™ and C-DRAGON™ draw the same power, regardless of the supply voltage. i.e. as the input voltage increases the current drawn decreases.

7.4 SYSTEM AND RADIO FEATURES

Radio Features	European Models	USA Models	
Working Frequency	433.92 MHz	910 MHz	
Bit Rate	19200	36800	
Range (in open air)	50 m	30 m	
System Configurations	OM-DRAGON™	STARGATE™	OM-6010-R
Maximum number of devices per base stations	32	255	32
Maximum number of devices in the same reading area	2000		127
Maximum number of base stations in network	16 (including cradle Master)		

7.5 STATUS INDICATORS

The reader has two indicator LEDs and a Beeper. The OM-DRAGON™ and C-DRAGON™ cradles have three indicator LEDs. They signal several operating conditions which are described in the tables below.

DRAGON™ D/M READER START-UP

Beeper ¹	Meaning
L L L L	Parameters loaded correctly
H H H H long tones	Parameter loading error, reading or writing error in the non volatile memory
H L H L	Hardware error in EEPROM

DRAGON™ D/M READER CONFIGURATION

Beeper ¹	Meaning
H H H H	Correct entry or exit from Configuration mode
L	Good read of a command
L L L	Command read error

DRAGON™ D/M READER DATA ENTRY

Beeper ¹	Red LED	Green LED	Meaning
	ON		Laser ON
one beep ²		ON	Correct read of a code in normal mode
H L long			TX buffer full (when FIFO is enabled) or TX error between DRAGON™ M and OM-DRAGON™
H long		ON	Successful advanced format concatenation
H H H			Timeout expired – operation not completed
H H long			Error in advanced data formatting
		OFF	Ready to read a code

¹ Only the Beeper Intensity command can modify these signals.

² The data entry good read tone is user-configurable with all the Beeper commands in the Reading Parameters section.

For M-series readers, normally this results in two beeps; the first indicates that the reader has decoded the code, the second indicates whether OM-DRAGON™ has received the data. See also par.5.8.4.

DRAGON™ M POWER

Beeper	Green LED	Meaning
10 short H	10 short blinks	Low Battery
H M L		Power off

H = high tone

M = medium tone

L = low tone

DRAGON™ M BIND, JOIN, COPY COMMANDS

Beeper ¹	Green LED	Meaning
	Blinking	Command accepted; reader ready to be inserted into the cradle
L		Success
H L long tones		Failure

OM-DRAGON™/C-DRAGON™ CHARGE STATUS

Red LED	Green LED	Meaning
ON	ON	Charging
OFF	ON	End of charge
OFF	OFF	No battery inserted
Flashing	OFF	Discharging (see par. 2.7.2)
Flashing	Flashing	Shorted or open battery

OM-DRAGON™/C-DRAGON™ POWER/COMMUNICATION

Yellow LED	Meaning
ON	Power applied
OFF	Error in reading EEPROM parameters
Blinking	Transmission over the Host port

7.6 READING DIAGRAMS

DRAGON™ D/M101

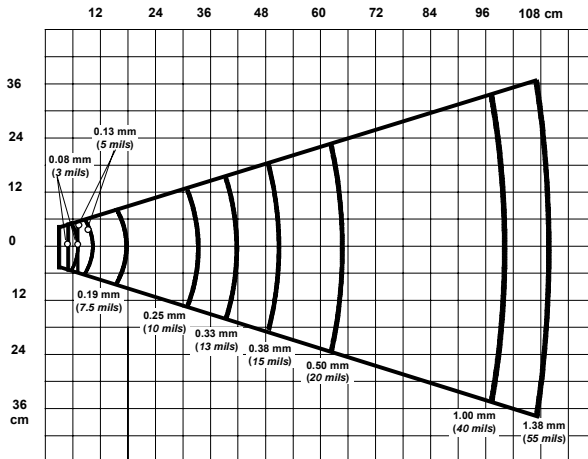

DRAGON™ D101 High Density

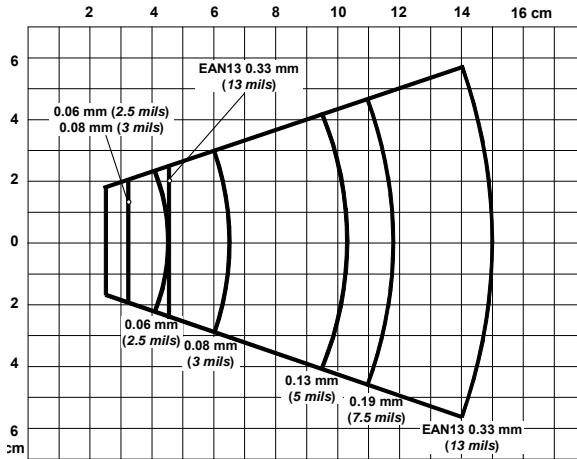

DRAGON™ D/M101 Long Range

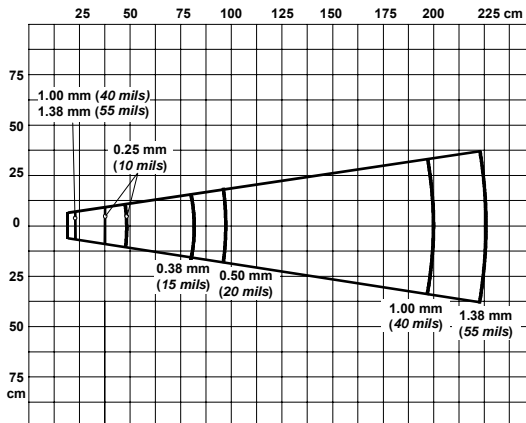

A HOST CONFIGURATION STRINGS

In this section we provide a description of how to modify the device configuration using serial strings sent from the Host.

This method requires the RS232 interface.

The device configuration can be changed by receiving commands from the Host through the serial interface. When this method is used, the programming sequence format is the following:

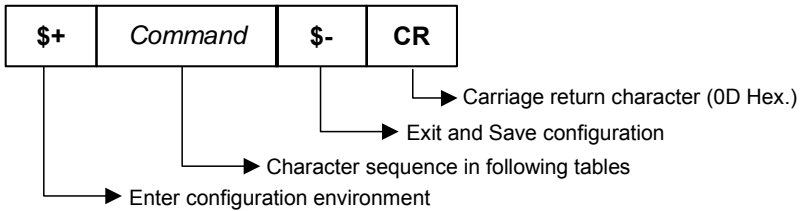

Example:

Multiple command programming sequence:

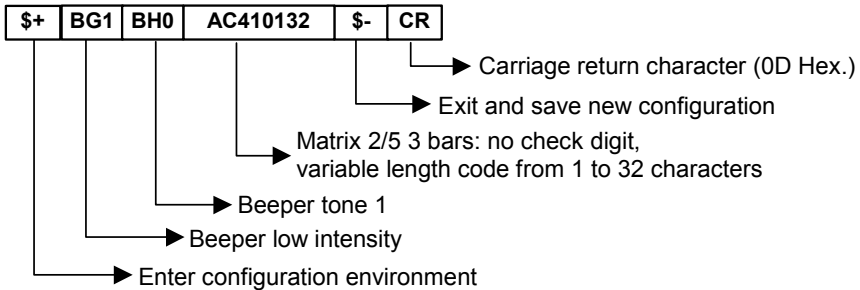

Each configuration parameter setting removes the condition previously active for that parameter.



NOTE

The device buffer can contain about 400 characters. If your programming string goes over this value, you must split it into separate groups and send each group after a delay of at least 3 seconds to give the reader time to empty the buffer and interpret the commands.

SERIAL CONFIGURATION STRINGS

ENTER/EXIT CONFIGURATION COMMANDS

DESCRIPTION	STRING
Enter Configuration	\$+
Exit and Save Configuration	\$-
Restore Default	\$*
Transmit Software Release (not for PEN emulation)	\$!
Transmit Device Configuration in ASCII (not for PEN emulation)	\$&

These commands do not require \$-.

INTERFACE SELECTION

DESCRIPTION	STRING
RS232	CP0
WEDGE for IBM AT	CP500
for IBM Terminals: 31xx, 32xx, 34xx, 37xx; make-break keyboard	CP501
for IBM Terminals: 31xx, 32xx, 34xx, 37xx; make-only keyboard	CP502
Keyboard Type for IBM Terminals 31xx, 32xx, 34xx, 37xx	FK0
typewriter	FK1
advanced	FK1
for IBM XT	CP503
for IBM Terminal 3153	CP504
for IBM PC Notebook	CP505
for IBM SURE1	CP506
for IBM AT - ALT mode	CP507
for IBM PC Notebook - ALT mode	CP508
for Wyse Terminal - ANSI Keyboard	CP509
for Wyse Terminal - PC Keyboard	CP510
for Wyse Terminal - ASCII Keyboard	CP511
for Wyse Terminal - VT220 style Keyboard	CP514
for Digital Terminals VT2xx/3xx/4xx	CP512
for Apple ADB Bus	CP513
PEN EMULATION	CP6

RS232

DESCRIPTION	STRING	
Baud rate	150	CD0
	300	CD1
	600	CD2
	1200	CD3
	2400	CD4
	4800	CD5
	9600	CD6
	19200	CD7
	38400	CD8
Parity	none	CC0
	even	CC1
	odd	CC2

RS232 (continued)		
Data bits	7	CA0
	8	CA1
	9	CA2
Stop bits	1	CB0
	2	CB1
Handshaking	disable	CE0
	RTS/CTS	CE1
	XON/XOFF	CE2
	RTA always On	CE3
ACK/NACK Protocol	disable	ER0
	enable	ER1
FIFO	disable	EC0
	enable	EC1
Inter-character delay (<i>ms</i>)		CK00 - CK99
RX Timeout (<i>100 ms</i>)		CL00 - CL99
Serial Trigger Lock (D series only)	disable	CR0
	enable and select characters	CR1ab

a = Hex values representing an ASCII character from **00** to **FE** enabling the device trigger.

b = HEX values representing an ASCII character from **00** to **FE** inhibiting the device trigger.

WEDGE		
DESCRIPTION		STRING
Keyboard nationality	Belgian	FJ7
	English	FJ4
	French	FJ2
	German	FJ3
	Italian	FJ1
	Spanish	FJ6
	Swedish	FJ5
	USA	FJ0
	Japanese	FJ8
	Russian (Latin)	FJ9
	Russian (Cyrillic)	FJA
	Hungarian	FJB
	Yugoslavian	FJC
	Romanian	FJD
Czechoslovakian	FJE	
Caps Lock	caps Lock ON	FE1
	caps Lock OFF	FE0
Caps Lock Auto-recognition	ENABLE	FP1
	DISABLE	FP0
Num Lock	Toggle Num Lock	FL1
	Num Lock Unchanged	FL0
Delays	Inter-Character (<i>ms</i>)	CK00 - CK99
	Inter-Code (<i>s</i>)	FG00 - FG99
Control Character Emulation	Ctrl + Shift + Key	FO0
	Ctrl + Key	FO1

PEN EMULATION		
DESCRIPTION		STRING
Operating mode	interpret (does not require \$+ or \$-)	\$]
	transparent (does not require \$+ or \$-)	\$[
Minimum output pulse	200µs	DG0
	400µs	DG1
	600µs	DG2
	800µs	DG3
	1 ms	DG4
	1.2 ms	DG5
Conversion to Code 39 and Code 128	disable conversion to Code 39 (D series only)	DA0
	enable conversion to Code 39	DA1
	enable conversion to Code 128 (M series only)	DA2
Output level	normal	DD0
	inverted	DD1
Idle level	normal	DE0
	inverted	DE1
Overflow	narrow overflow	DH0
	medium overflow	DH1
	wide overflow	DH2
Inter-Block delay (100 ms)		CK00-CK99

NETWORK		
DESCRIPTION		STRING
RS485 Network	Disable Network	RZ0
	Enable RS485 Slave	RZ1
	Enable RS485 Master	RZ2
Slave Address Range	Minimum Address	JB0000-1999
	Maximum Address	JC0000-1999
Network Baud Rate	9600	JE0
	19200	JE1
	38400	JE2
Warning Message	not transmitted	JG0
	transmitted	JG1
Master Header	no header	JA00
	one character	JA01x
	two characters	JA02xx
	three characters	JA03xxx
	four characters	JA04xxxx
	five characters	JA05xxxxx
	six characters	JA06xxxxxx
	seven characters	JA07xxxxxxx
eight characters	JA08xxxxxxxx	

x = Hex value from 00 to FE representing an ASCII character

NETWORK (continued)		
DESCRIPTION	STRING	
Master Terminator	no terminator	JA10
	one character	JA11x
	two characters	JA12xx
	three characters	JA13xxx
	four characters	JA14xxxx
	Five characters	JA15xxxxx
	six characters	JA16xxxxxxx
	seven characters	JA17xxxxxxxx
eight characters	JA18xxxxxxxxx	

x = Hex value from **00** to **FE** representing an ASCII character

DATA FORMAT		
NOT FOR PEN EMULATION INTERFACES		
DESCRIPTION		STRING
Code Identifier	Disable	EB0
	Datologic standard	EB1
	AIM standard	EB2
	Custom	EB3
Custom Code Identifier		EHabc
Headers	no header	EA00
	one character	EA01x
	two characters	EA02xx
	three characters	EA03xxx
	four characters	EA04xxxx
	five characters	EA05xxxxx
	six characters	EA06xxxxxx
	seven characters	EA07xxxxxxx
eight characters	EA08xxxxxxxxx	
Terminators	no terminator	EA10
	one character	EA11x
	two characters	EA12xx
	three characters	EA13xxx
	four characters	EA14xxxx
	five characters	EA15xxxxx
	six characters	EA16xxxxxx
	seven characters	EA17xxxxxxx
eight characters	EA18xxxxxxxxx	
Code Length Tx	not transmitted	EE0
	transmitted in variable-digit format	EE1
	transmitted in fixed 4-digit format	EE2

a = ASCII character.

b, c, x = HEX values representing an ASCII character.

a = ASCII character of the DATALOGIC STANDARD Code Identifier from the table on page 65.

b = Hex value of the first Custom Code Identifier character from **00** to **FE**;

FF = disable Code Identifier

c = Hex value of the second Custom Code Identifier character from **00** to **FE**;

FF = disable second character of Custom Code Identifier

x = Hex value from **00** to **FE**

DATA FORMAT (continued)		
NOT FOR PEN EMULATION INTERFACES		
DESCRIPTION		STRING
Field Adjustment	Disable	EF0
	right addition	EFa0d
	left addition	EFa1d
	right deletion	EFa2d
	left deletion	EFa3d
Field Adjustment Character		EGe
Character Replacement	disable character replacement	EO0
	first character replacement	EO1afg
	second character replacement	EO2afg
	third character replacement	EO3afg
Address Stamping	disable reader address stamping	RU0
	enable reader address stamping	RU1
	disable cradle address stamping	RW0
	enable cradle address stamping	RW1
Address Delimiter	disable reader address delimiter	RV0
	enable reader address delimiter and select character	RV1h
	disable cradle address delimiter	RY0
	enable cradle address delimiter and select character	RY1h
Time Stamping	Disable	IL0
	hour/minutes/seconds/month/day/year	IL1
	hour/minutes/seconds/day/month/year	IL2
	hour/minutes/seconds	IL3
	month/day/year	IL4
	day/month/year	IL5
Time Stamping Delimiter	disable time stamping delimiter	IM0
	enable time stamping delimiter and select character	IM1h

- a** = ASCII character.
- d** = a number from the Hex/Numeric Table
- e, f, g h** = HEX values representing an ASCII character

a = ASCII character of the DATALOGIC STANDARD Code Identifier from the table on page 65.

d = a number in the range **01-32** from the Hex/Numeric Table

e = Hex value from **00** to **FE**

f = Hex value of the character to be replaced from **00** to **FE**

g = Hex value of the new character to insert from **00** to **FE**
FF = replace with no new character (remove character)

h = a HEX value in the range from **00** - **FE** representing the ASCII character.

POWER SAVE		
DESCRIPTION		STRING
Sleep State	disable	BQ0
	enable	BQ1
Enter Sleep Timeout (100 ms)		BR00-BR99

READING PARAMETERS		
DESCRIPTION		STRING
Trigger Type	software trigger	BK0
	hardware trigger	BK1
Trigger Signal	trigger active level	BA0
	trigger active pulse	BA1
Trigger-off Timeout (s)		BD00 - BD99
FLASH ON (100 ms)		BB001 - BB099
FLASH OFF (100 ms)		BB101 - BB199
Reads per Cycle	one read	BC0
	multiple reads	BC1
Safety Time (100 ms)		BE00 - BE99
Beeper Intensity	very low intensity	BG0
	low intensity	BG1
	medium intensity	BG2
	high intensity	BG3
Beeper Tone	tone 1	BH0
	tone 2	BH1
	tone 3	BH2
	tone 4	BH3
Aiming System	disabled	BX0
	300 ms	BX1
	500 ms	BX2
	1 second	BX3

DECODING PARAMETERS		
DESCRIPTION		STRING
Ink-spread	Disable	AX0
	Enable	AX1
Overflow control	Disable	AW1
	enable	AW0
Interdigit control	disable	AV0
	enable	AV1
Puzzle Solver™	disable	AU0
	enable	AU1
Decoding Safety	one read	ED0
	two reads	ED1
	three reads	ED2
	four reads	ED3

CODE SELECTION			STRING
DISABLE ALL FAMILY CODES			AZ0
EAN/UPC	disable EAN/UPC family		AA0
	EAN 8/EAN 13/UPC A/UPC E	without ADD ON	AA1
		with ADD ON	AA5
		with and without ADD ON	AA8
	EAN 8/EAN 13	without ADD ON	AA3
		with ADD ON 2 ONLY	AAK
		with ADD ON 5 ONLY	AAL
		with ADD ON 2 AND 5	AA6
	UPC A/UPC E	without ADD ON	AA4
		with ADD ON 2 ONLY	AAM
		with ADD ON 5 ONLY	AAN
		with ADD ON 2 AND 5	AA7
	EAN 8 check digit transmission	disable	AAG0
		enable	AAG1
	EAN 13 check digit transmission	disable	AAH0
		enable	AAH1
	UPC A check digit transmission	disable	AAI0
		enable	AAI1
	UPC E check digit transmission	disable	AAJ0
		enable	AAJ1
Conversions	UPC E to UPC A		AAA
	UPC E to EAN 13		AAB
	UPC A to EAN 13		AAC
	EAN 8 to EAN 13		AAD
ISBN Conversion codes	enable ISBN		AP1
	enable ISSN		AP2
	enable ISBN and ISSN		AP3
	disable ISBN and ISSN		AP0
Code 39	disable Code 39 family		AB0
	Standard	no check digit control	AB11
		check digit control and transmission	AB12
		check digit control without transmission	AB13
	Full ASCII	no check digit control	AB21
		check digit control and transmission	AB22
check digit control without transmission		AB23	

CODE SELECTION (continued)			
DESCRIPTION		STRING	
Code 39	CIP 39	AB3	
	Code 32	AB4	
	code length	AB*xxxx	
2/5	disable Code 2/5 family		AC0
	Interleaved 2/5	no check digit control	AC11xxxx
		check digit control and transmission	AC12xxxx
		check digit control without transmission	AC13xxxx
	Normal 2/5 5 bars	no check digit control	AC21xxxx
		check digit control and transmission	AC22xxxx
		check digit control without transmission	AC23xxxx
	Industrial 2/5 (IATA)	no check digit control	AC31xxxx
		check digit control and transmission	AC32xxxx
		check digit control without transmission	AC33xxxx
	Matrix 2/5 3 bars	no check digit control	AC41xxxx
		check digit control and transmission	AC42xxxx
		check digit control without transmission	AC43xxxx
	CIP/HR	AC5	
Codabar	disable Codabar family		AD0
	Standard	no start/stop character equality control nor transmission	AD111
		no start/stop character equality control but transmission	AD112
		start/stop character equality control but no transmission	AD121
		start/stop character equality control and transmission	AD122
	ABC Codabar	no start/stop character equality control but transmission	AD212
	Codabar ABC forced concatenation		AD232
	code length		AD*xxxx
	start/stop character case in transmission	lower case	ADA0
		upper case	ADA1

xxxx = ASCII numbers that define the code length where:

- First 2 digits = minimum acceptable code length.
- Second 2 digits = maximum acceptable code length.

The minimum code length must always be less than or equal to the maximum.

The maximum code length for all codes is 99 characters:

Examples:

0132 = variable length from 1 to 32 digits in the code.

1010 = 10 digit code length only.

CODE SELECTION (continued)		
DESCRIPTION		STRING
Code 128	disable Code 128 family	A10
	enable Code 128 - control without transmission of check digit	A111
	enable EAN 128 - control without transmission of check digit	A121
	transmit GS before Code	disable EQ0 enable EQ1
	ISBT 128	enable ISBT 128 A131
	code length	AILxxxx
Code 93	disable Code 93 family	AK0
	enable Code 93 - control without transmission of check digit	AK1
MSI	disable the family	AE0
	no check	AE1
	MOD10 no tx	AE2
	MOD10 with tx	AE3
	MOD11-MOD10 no tx	AE4
	MOD11-MOD10 with tx	AE5
	MOD10-MOD10 no tx	AE6
	MOD10-MOD10 with tx	AE7
Plessey	disable the family	AF0
	Standard no check	AF11
	Standard check - with tx	AF12
	Standard check - no tx	AF13
	Anker no check	AF21
	Anker check - with tx	AF22
	Anker check - no tx	AF23
Telepen	disable the family	AL0
	Numeric no check	AL11
	Numeric check - with tx	AL12
	Numeric check - no tx	AL13
	Alpha no check	AL21
	Alpha check - with tx	AL22
	Alpha check - no tx	AL23
Delta IBM	disable the family	AH0
	no check	AH1
	Type 1 check	AH2
	Type 2 check	AH3

xxxx = ASCII numbers that define the code length where:

- First 2 digits = minimum acceptable code length.
- Second 2 digits = maximum acceptable code length.

The minimum code length must always be less than or equal to the maximum.
The maximum code length for all codes is 99 characters:

Examples:

- 0132 = variable length from 1 to 32 digits in the code.
- 1010 = 10 digit code length only.

CODE SELECTION (continued)		
DESCRIPTION		STRING
Code 11	disable the family	AG0
	no check	AG1
	Type C with tx	AG21
	Type C no tx	AG22
	Type K with tx	AG31
	Type K no tx	AG32
	Type C and K with tx	AG41
	Type C and K no tx	AG42
Code 16K	Disable	AJ0
	Enable	AJ1
Code 49	Disable	AM0
	enable	AM1
RSS Codes	disable the family	AQ0
	disable RSS Expanded Linear and Stacked	AQ10
	enable RSS Expanded Linear and Stacked	AQ11
	disable RSS Limited	AQ20
	enable RSS Limited	AQ21
	disable RSS 14 Linear and Stacked	AQ30
	enable RSS 14 Linear and Stacked	AQ31

RADIO PARAMETERS		
DESCRIPTION		STRING
Radio Protocol Timeout	enable (seconds)	RH02-RH19
Power-Off Timeout		RP00-RP99
Transmission Mode	one-way	RI0
	two-ways	RI1
Beeper Control For Radio Response	normal	BF0
	only good decode	BF1
	only good reception	BF2
	off	BF3
Battery Type	alkaline	RB0
	NiMh	RB1
	auto-detect	RB2
Single Store	disable	RO0
	one attempt	RO1
	two attempts	RO2
	three attempts	RO3
	four attempts	RO4
	five attempts	RO5
	six attempts	RO6
	seven attempts	RO7
	eight attempts	RO8
nine attempts	RO9	

DISPLAY PARAMETERS		
DESCRIPTION		STRING
Date		IAddmmyy
Time		IBhhmm
Contrast	lighter	IC0
	darker	IC1
Font Size	small	ID0
	medium	ID1
	large	ID2
Backlight	off	IE0
	on	IE1
Display-Off Timeout		Ifa
Display Mode	normal	IG0
	local echo	IG1
	clear display after decode	IG2
Keypad	disabled keys	IK0
	enable and select KeyID characters	IK1bbb

- ddmmyy** = numbers from the Hex/Numeric Table representing day, month, year
- hhmm** = numbers from the Hex/Numeric Table representing hour, minutes
- a** = a number from the Hex/Numeric Table
- b** = HEX values representing an ASCII character

a = a number in the range **00-99** (sec.) from the Hex/Numeric Table
00 = Timeout disabled (always on).

b = 3 Hex values from **00** to **FE** representing the left, center and right keys.
FF = KeyID disabled.

B CODE IDENTIFIER TABLE

2/5 Interleaved



2/5 normal 5 bars



EAN 8



UPC A



EAN 8 with 2 ADD ON



EAN 13 with 2 ADD ON



UPC A with 2 ADD ON



2/5 Industrial



2/5 matrix 3 bars



EAN 13



UPC E



EAN 8 with 5 ADD ON



EAN 13 with 5 ADD ON



UPC A with 5 ADD ON



UPC E with 5 ADD ON



Code 39 Full ASCII



ABC CODABAR



EAN 128



CIP/39



Code 32



UPC E with 2 ADD ON



Code 39



CODABAR



Code 128



Code 93



CIP/HR



ISBT 128

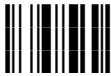

Plessey Anker**Delta IBM****Code 16K****Code 49****RSS Limited****MSI****Plessey Standard****Telepen****Code 11****RSS Expanded Linear and Stacked****RSS 14 Linear and Stacked**

C HEX AND NUMERIC TABLE

**OPEN THIS PAGE TO READ THE DESIRED
HEX AND NUMERIC SELECTIONS**

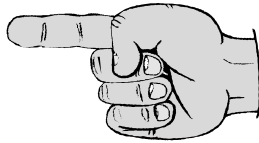

CHARACTER TO HEX CONVERSION TABLE

char	hex	char	hex	char	hex
NUL	00	*	2A	U	55
SOH	01	+	2B	V	56
STX	02	,	2C	W	57
ETX	03	-	2D	X	58
EOT	04	.	2E	Y	59
ENQ	05	/	2F	Z	5A
ACK	06	0	30	[5B
BEL	07	1	31	\	5C
BS	08	2	32]	5D
HT	09	3	33	^	5E
LF	0A	4	34	~	5F
VT	0B	5	35	a	60
FF	0C	6	36	b	61
CR	0D	7	37	c	62
SO	0E	8	38	d	63
SI	0F	9	39	e	64
DLE	10	:	3A	f	65
DC1	11	;	3B	g	66
DC2	12	<	3C	h	67
DC3	13	=	3D	i	68
DC4	14	>	3E	j	69
NAK	15	?	3F	k	6A
SYN	16	@	40	l	6B
ETB	17	A	41	m	6C
CAN	18	B	42	n	6D
EM	19	C	43	o	6E
SUB	1A	D	44	p	70
ESC	1B	E	45	q	71
FS	1C	F	46	r	72
GS	1D	G	47	s	73
RS	1E	H	48	t	74
US	1F	I	49	u	75
SPACE	20	J	4A	v	76
!	21	K	4B	w	77
"	22	L	4C	x	78
#	23	M	4D	y	79
\$	24	N	4E	z	7A
%	25	O	4F	{	7B
&	26	P	50		7C
'	27	Q	51	~	7D
(28	R	52	DEL	7E
)	29	S	53		7F
		T	54		

HEX / NUMERIC TABLE



0



1



2



3



4



5



6



7



8



9



A



B



C



D



E



F

Backspace

Cancels an incomplete configuration sequence



90ACC1855